



Security and Intelligence Advising

EXPORT PRODUCT CATALOG

<u>Subject</u>	<u>Page</u>
COFDM Digital Video Transmitter.....	2
MPEG 4 Professional digital Video Recorders.....	3
Miniature Audio Video Transmitters.....	6
Encrypted Audio Video Transmitter.....	10
High Power Audio Video Transmitters.....	11
Personal Audio Video Transmitters.....	16
Wireless Camera Hunter.....	21
Hidden Wireless Cameras.....	22
Hidden Cameras.....	25
Tactical Helmet Cameras.	33
Professional Bug Detection Equipment.....	35
Professional Cell Phone Jammers.....	38
Audio Transmitters and Receivers.....	45
Wall Contact Microphones.....	53
Digital Radio Microphone	55
VIP Protection System.....	57
Electronic Ambush system.....	58
Powerful Hand Held Hidden Surveillance System....	59
SpyPhone.	60
Security Encrypted Mobile Phones.....	61
Untraceable Mobile phone.....	62
Recording Mobile Phone.....	63
Miniature In Ear Earphones.....	64
Infra Red Illuminators.....	65
MPEG 2 Professional Video Recorders.....	67
Through Wall Radar.....	71
Optical Microphone.....	72
Optic Inspection Systems.....	73
Thermal Cameras.....	74
Vibro – Acoustic Noise Generator.....	78
Portable Flat Panel X-RAY Inspection System.....	82
Bullet Proof Protection Gear.....	83
Investigation Aerosol Products	85

**COFDM Digital Video Transmitter
Ultra Small, High Power**



Security and Intelligence Advising

The HB6100 video link is based on a digital transmission modulation called COFDM. The COFDM technique allows sending data on multiple carriers, while using digital constellations as QPSK and QAM.

This kind of modulation allows large bit rates with the ability to send enough data and coding to receive higher sensitivity and immunity to multi-path. This ability allows the system to operate when there is no line –of – sight, a media where analog Video fails. The HB6100 is the smallest COFDM video transmitter in the market.

Specifications:

Frequency: L,S-Band

Frequency Stability: ± 5 ppm

Output Power : 27 dBm Linear (0.5W)

Output Impedance: 50 Ohm ,VSWR 2:1 max

RF Band-Width: 2.5MHz

Video format: PAL/NTSC

Modulation: QPSK

ENCODING:MPEG2

Bit Rate: 2.4MBPS Typical.

Supply Voltage: 8 - 16Vdc

Power consumption: <8W

ENVIRONMENTAL:

Temperature: $-25^{\circ}\text{C} \div +85^{\circ}\text{C}$

MECHANICAL:

Size: 70 x67 x23 mm (excluding connectors)

Weight: 142 grm

Connectors: RF –SMA FEMALE, Video, dc,-9 Pin MDM Connector

OPTIONAL

Audio input: 1 Vptp, STEREO

ENCRPTION: AES128/256

Video Encoding: MPEG 4

MODULATION: 16-QAM.

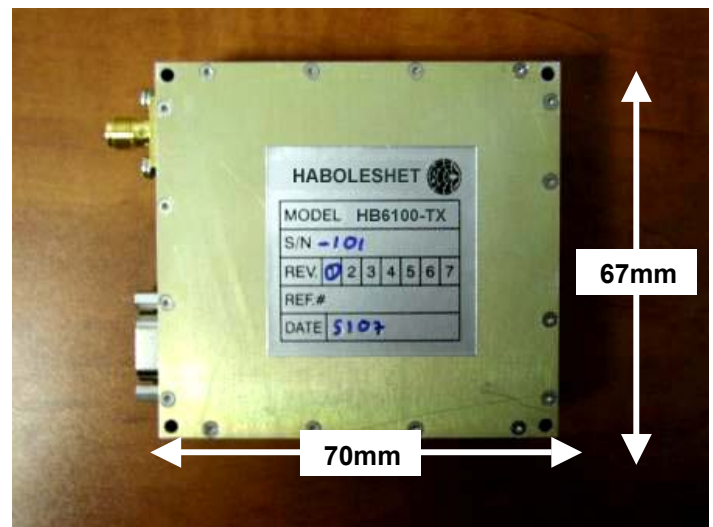



Security and Intelligence Advising

PVR-1235CK & PVR-1235SDCK

Feature

Synergistic design

Designed to be assembled and broken down easily, without the need for any tools. This allows you to use it as an independent remote unit or fully assembled according to your needs.

Dual frequencies and multi-channels

The unit will work on either 1.2 GHz or 2.4 GHz wireless frequencies. In addition there are 32 channels to choose from covering all of those used on the market.

Specification

Model	PVR-1235CK	PVR-1235SDCK
Frequency	1.2 & 2.4GHz	
No. Of Channel	1.2GHz 14 Ch's/ 2.4GHz 8Ch's	
Audio Sub-Carrier	5.5MHz at 1.2GHz/6.5MHz at 2.4GHz	
Phase Lock Loop	Built-In	
Antenna Connector	SMA Female	
Video Display	3.5" RGB 320x240 Color TFT LCD	
Resolution	D1 720X480@NTSC/640x480@PAL	
Recording Mode	Manual / Event / Loop/ Schedule	
Watermark	Frame Counter	
Frame Rate	18 to 30 fps	
Storage	1.8"30GB HDD &SD	SD Card only
A/V IN	2.5mm A/V In & DC 5V Out for Camera	
A/V IN	3.5mm A/V In & DC 12V Out for Camera	
Audio/Video Output	3.5mm Phone Jack	
USB Jack	Mini USB 2.0high speed	
Power	DC 5V 2 Amp IN	
Consumption Current	950mA	
Battery	2000mA 3.7V(NP-120 Rechargeable)	
Dimenssion	146(W) x 64(H) x 88(T) mm	
Weight	405g	355g

Above Specific ation subject to change with out notice

Standard Package for PV-1235CK/PV-1235SDCK PVR Receiver Kit

PV-800CK Complete Kit RX-1290 Full Range RX Antenna Grip/ Stand Visor

Standard Package for RX-1290CK stand-alone Receiver Kit

RX-1290 Full Range RX Antenna Grip/ Stand Visor

Specialized software

The PV800 high performance camera comes with software that allows you to set recording parameters to allow you to carry out all kinds of monitoring work

Fixed and mobile surveillance

By simply plugging in a wall adapter this unit can carry out long-term fixed position surveillance. However the built-in battery also allows you to take the unit with you and use it as a hand-held Surveillance device

Choosing between wired and wireless

It is easy to switch the unit between its wired and wireless modes to quickly suit your needs. The equipment includes facility to act as a power source to offer extended run time in remote locations such as surveillance situations. The unit is well suited to use inside and out of a car.

Sun visor

The built in visor allows the unit to be used even on very bright days. The unit works well even when moving from indoors to outdoors, no adjustment will be needed to compensate for any change in Brightness.





Security and Intelligence Advising

PV-800 /W Built-In 1.8" HDD & SD Slot Series

Feature

Super High Resolution

Able to record 720x480 super high resolution picture quality into built-in 1.8" 30GB hard drive disc memory & SD card slot read up to 4GB

Output power supply

Featuring direct both DC5V &12V power output to support most CCD cameras. Additional battery for camera is now a thing of past

Recording Oriented Designed

Every feature are designed to support the user to achieve the surveillance recording task perfectly under most crucial scenario & condition

Multiple Recording Mode

Including Manual/Auto/**Motion Detection**/Schedule For different scenario & environment use

Tamper-Proof Frame Counter

Watermarked with a counter indication in each frame. The recorded video file is tamper proof, a solid evidence for law enforcement units

High capacity Battery

Utilized 1800 mA/3.7V high capacity FUJI camcorder rechargeable battery. It is easy to get from a video shop and maximizes operating time

Cable Remote Control

Cable Remote Controller Module Device supported optionally, making the recorder more concealed with fully instant control capability

Specification

Model Number	PV-800
Display	320xRGBX240 3.5" colour TFT-LCD
Video Input	NTSC/PAL Standard
Video Recording Mode	Auto/Manual/ Motion Detection /Schedule
Memory Supported	1.8" 30GB HDD & SD Card (up to 4GB)
Recording Time	65 Minutes/ 1 G SD Card
Video Recording	Encode:720 x480 Pixels@16~18fps/AVI Decode:640 x480 Pixels@25~30fps/AVI
Audio Recording	Yes
Photo Recording	Yes
Dual A/V Input	Both 2.5 & 3.5mm AV Input Jack
PC Interface	Mini USB2.0
Consumption Current	800mA
Power to Camera	DC 5V Output at 2.5mm AV Input Jack DC 12V Output at 3.5mm AV Input Jack
Battery Type	Removable 3.7V/1.8 Amp Lithium Battery
Battery Lifetime	180 Minutes(Including External CCD Power)
Dimension	130 (L) x83 (W) x26 (H) mm
Weight	263/313g with/out the battery respectively



*Specification & appearance may be subjected to change without notice

Standard Accessories

DC3.7V/ 1.8A Lion Battery DC 5V Charger Carrying Case Earphone
USB & AV Output Cable Camera Input Cable User's Guide Disc

Optional Accessories

Various Sizes of SD Memory Card Various Type Compatible Covert Camera Series
*Wired Type Cable Remote Controller **Wireless Type Cable Remote Controller



Security and Intelligence Advising

PV-700 With LCD Monitor Series

Feature

Super High Resolution

Able to record 720x480 super high resolution quality picture into SD memory card contains 1 to 2 GB for about 70 ~280 minutes at real time status

Power to Camera supply

Able to power the outside various camera which work with for both 5V & 12V applying almost all kind of existed cameras

High capacity Battery

Using FUJI NP-120 1800 mA/5V high capacity mini cell-phone type rechargeable battery for easy-to-get to extend the power life time

Multiple Recording Mode

Including Manual/Auto/Motion Detect/Schedule for different scenario & environment use

Tamper-Proof Frame Counter

Watermarked with a counter indication in each frame. The recorded video file is tamper proof, a solid evidence for law enforcement units

Operation & Low-Bat Vibration Alert

Equipped tiny-motor to make vibrate alert while Power on/off, recording & low-bat. Enabling more intelligent & concealed operation with no sight

Cable & Non-cable remote control capability

Optionally equip with the Cable remote controller & RF remote controller for various demand & application

Specification

Item Number	PV-700
Display	2.4 TFT LCD
Video Input	NTSC/PAL Standard
Video Recording Mode	Auto/Manual/ Motion Detection/Schedule
Resolution	720 x480@18fps / 640x480@30fps
Memory Type	SD Card(Supporting to 2GB)
Recording Time	65 Minutes/ 1 G SD Card
Power to Camera	DC 5V Output at 2.5mm AV Input Jack DC 12V Output at 3.5mm AV Input Jack
Remote Control	Optional Cable controller / RF controller
PC Interface	USB2.0
Output Power Consumption	DC 5V@ 250mA MAX & DC12V@250mA MAX
Date/Time Table	YYYY/MM/DD, HH,MM,SS
Vibration Alert	Power on/off, Recording , Low-Battery
Power Supply	DC 5V
Operation Current	650 mA
Battery Type	DC 3.7V/1.8 Amp Lithium-Iron Battery
Battery Lifetime	130Minutes(Including External CCD Power)
Dimension	95x55x25 mm
Weight	100g (without Battery)



Standard Accessories

DC 3.7V/1.8A
Li-On Battery

USB & AV
Lead Cable

DC 5V Charger

Hard Carrying
Case

Earphone

Optional Accessories

1 and 2GB
SD Card

Wired Covert
Camera Series

Concealed
Shoulder belt

Cigarette light
head Switcher

Hi-Sensitive
Amplified MIC

*Cable Remote Controller

**RF Wireless Remote Controller

TM-121800/ TM-241800 A/V Transmitter Module

Feature

- 1.2 & 2.4GHz Band frequency transmission option
- Highly integrated circuit / High power output (1Watt).
- High Reliability/Linearity/AlGaAs/GaAs FET power amplifier module built-in
- Using digital phase-Lock-Loop circuit without drifting problem under high temp. Occasion
- 8 channels DIP switch selectable.

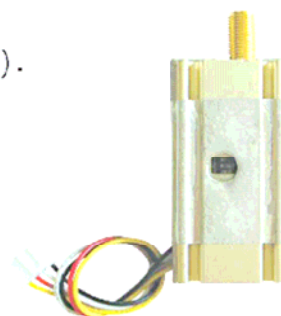

Specification

Item Number	TM-121800	TM-241800
Frequency Band	1200MHz	2400MHz
Available Channel	8 Ch	8 Ch
Audio Sub-Carrier	5.5 Mhz	6.5MHz
Trans. Range	500 Meter	
Consumption Current	450 mA	
Output Power	1000 mW	
Operation Voltage	12 V	
Power Supply	12V / 500mA	
Antenna Connector	SMA Connector	
Weight (TX)	30 g	
Dimension (TX)	26x 50x 13 mm	
Matched Receiver	RX-1260 & RX-1280B	RX-2460 & RX-2480B

Mechanical Sketch

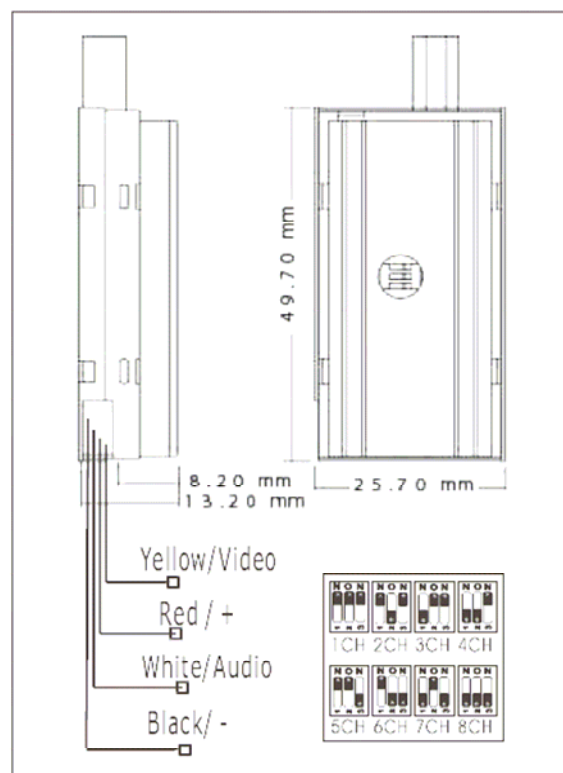

*Specification & appearance may be subjected to change without notice

Standard Shipping Package

- AV Transmitter Module * 1
- Standard Dipole Antenna * 1
- AV & power Switching Cable * 1

TM-120500/ TM-240500LM A/V Transmitter Module

Feature

- 1.2 & 2.4GHz Band frequency transmission option
- Highly integrated circuit / High power output (0.5Watt)
- High Reliability/Linearity/AlGaAs/GaAs FET power amplifier module built-in
- Using digital phase-Lock-Loop circuit without drifting problem under high temp. Occasion
- Ultra-mini compact size, ultra low power consumption

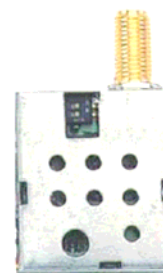

Specification

Item Number	TM-120500LM	TM-240500LM
Frequency Band	1200MHz	2400MHz
Available Channel	3 Ch	8 Ch
Audio Sub-Carrier	5.5 Mhz	6.5MHz
Trans. Range	200~500 Meter	
Consumption Current	450 mA	
Output Power	500 mW	
Operation Voltage	5~5.5 V	
Power Supply	5V / 500mA	
Antenna Connector	SMA Connector	
Weight (TX)	10 g	
Dimension (TX)	24x 28x 7 mm	
Matched Receiver	RX-1260 & RX-1280B	RX-2460& RX-2480B

Mechanical Sketch

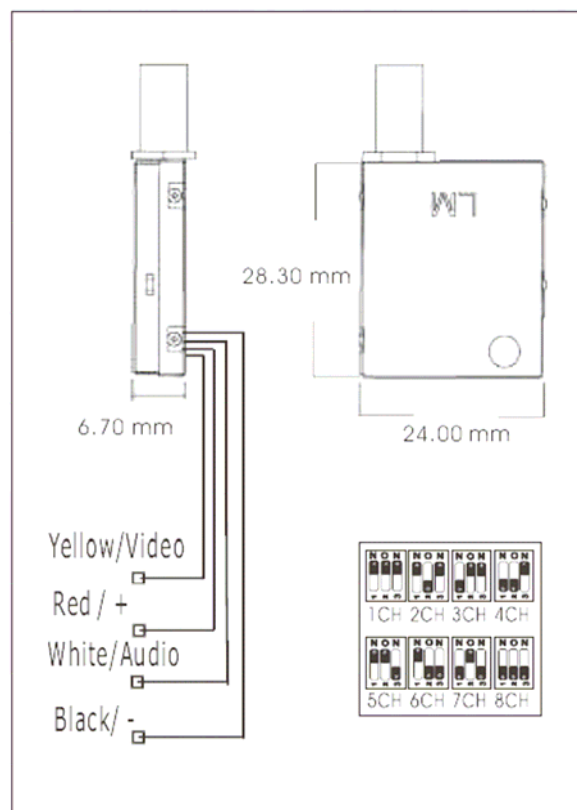

*Specification & appearance may be subjected to change without notice

Standard Shipping Package

- AV Transmitter Module * 1
- Standard Dipole Antenna * 1
- AV & power Switching Cable * 1



Security and Intelligence Advising

TM-120200 / TM-240200mini A/V Transmitter Module

Feature

- 1.2 & 2.4GHz Band frequency transmission option
- Highly integrated circuit / High power output (0.1Watt)
- High Reliability/Linearity/AlGaAs/GaAs FET power amplifier module built-in
- Using digital phase-Lock-Loop circuit without drifting problem under high temp. Occasion
- Bendable un-detached antenna designed for better concealed installed or application



Specification

Item Number	TM-120200mini	TM-240200mini
Frequency Band	1200MHz	2400MHz
Available Channel	3 Ch	4 Ch
Audio Sub-Carrier	5.5 Mhz	6.5MHz
Trans. Range	100~200 Meter	
Consumption Current	280 mA	
Output Power	100 mW	
Operation Voltage	5~5.5 V	
Power Supply	12V / 500mA	
Antenna Connector	Un-detached Type	
Weight (TX)	10 g	
Dimension (TX)	21x 24x 7 mm	
Matched Receiver	RX-1260 & RX-1280B	RX-2460& RX-2480B

Mechanical Sketch

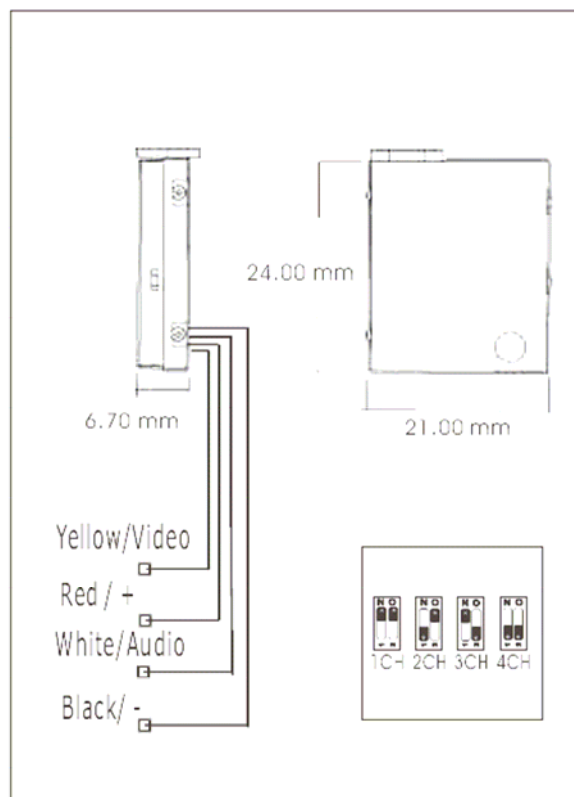

*Specification & appearance may be subjected to change without notice

Standard Shipping Package

- AV Transmitter Module *1
- Standard Dipole Antenna *1
- AV & power Switching Cable *1

TM-120200/ TM-240200 A/V Transmitter Module

Feature

- 1.2 & 2.4GHz Band frequency transmission option
- Highly integrated circuit/ High power output (0.2Watt)
- High Reliability/Linearity/AlGaAs/GaAs FET power amplifier module built-in
- Using digital phase-Lock-Loop circuit without drifting problem under high temp. Occasion
- Miniature & compact designed

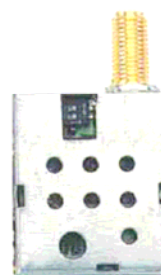

Specification

Item Number	TM-120200	TM-240200
Frequency Band	1200MHz	2400MHz
Available Channel	3 Ch	4 Ch
Audio Sub-Carrier	5.5 Mhz	6.5MHz
Trans. Range	100~200 Meter	
Consumption Current	280 mA	
Output Power	200 mW	
Operation Voltage	5~5.5 V	
Power Supply	5V / 500mA	
Antenna Connector	SMA Connector	
Weight (TX)	10 g	
Dimension (TX)	24x 28x 7 mm	
Matched Receiver	RX-1260 & RX-1280B	RX-2460& RX-2480B

Mechanical Sketch

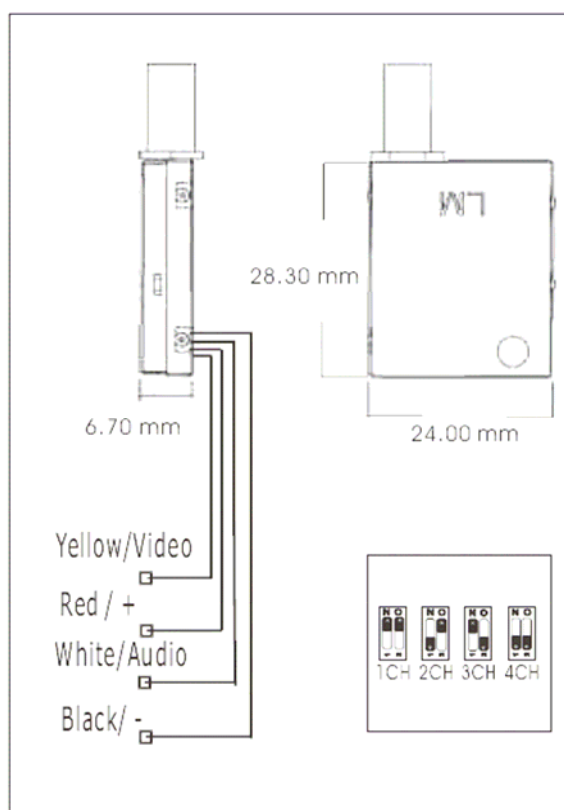

*Specification & appearance may be subjected to change without notice

Standard Shipping Package

- AV Transmitter Module * 1
- Standard Dipole Antenna * 1
- AV & power Switching Cable * 1



Security and Intelligence Advising

RF Wireless Encryption/Decryption Device Series

This state of the art device uses advanced digitally encryption method to provide secured video images over both cable and RF transmission mediums preventing general interception. When used in RF applications the traditional problems of noise causing the system to fail have been erased, producing a very stable platform for trouble free use. Supplied in stand-alone and sender built-in ruggedly housed formats are compatible with our wireless RF device and any existing Wire CCTV equipment with ultra small size and low cost.

ENT-121800/241800 Encryption Sender



1. Frq.: 1.2GHz / 2.4 Ghz
2. Channel: 8 CH's
3. Output: 1W/Min
4. Range: 150 ~ 400 Metres
5. Encryption: 2^{16} Times
6. Size: 54 x 82 x 36 mm
7. Power: DC12V/1000 mA
8. Weight: 110g

DNR-1200/ 2400 Decryption Receiver



1. Frq.: 1.2 / 2.4Ghz
2. Channel: 8 CH's
3. Switcher: Auto & Manual
4. Encryption: 2^{16} Times
5. Size: 80x80x35mm
6. Power: DC12V/ 500 mA
7. Weight: 220g

How the system work

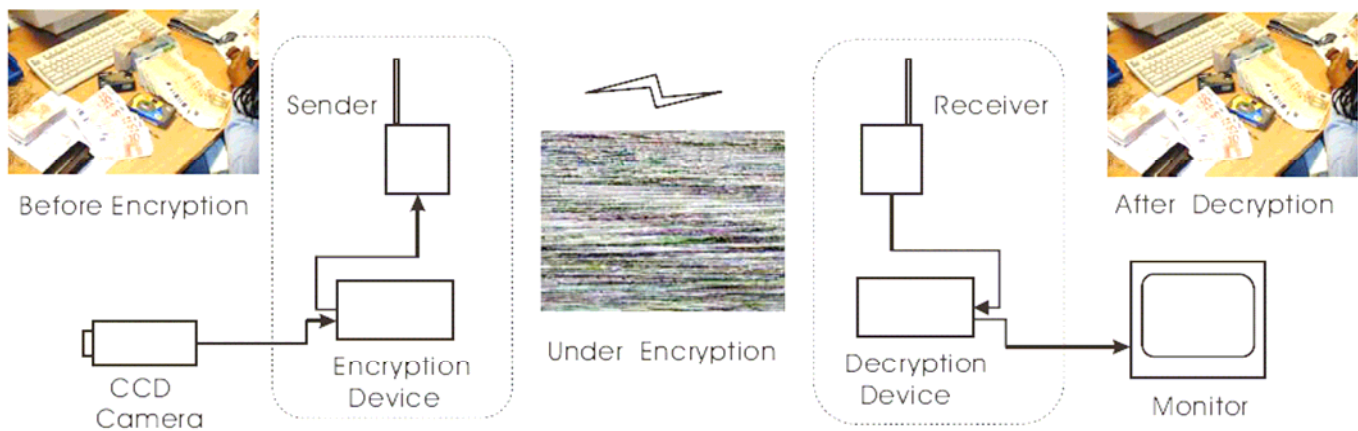

ENT-121800/241800

DNR- 1200/ 2400

Simply connect the encryption device to the video source output. The signal is then digitally encrypted using the "cut and rotate" encoded method. The encrypted video can then be transmitted securely. The video receiver output is then decrypted by the decryption device before being viewed on the monitor.



Security and Intelligence Advising

RXS-2460 / RX-1260

Feature

- Auto/Manual DIP switcher
- 8-Channel Option A/V Receiver Device
- Compact Size, no cable difficulty
- Producing clear audio affect & stable video affect
- Being able to hook up to 8 cameras and sending signals simultaneously



Standard Shipping Package

	CHANNEL ALLOCATION		1.2 GHz		2.4 GHz	
	1.2 & 2.4GHz /w 8 CH	CH1	CH5	1080	1010	2410
CH2		CH6	1120	1040	2430	2390
CH3		CH7	1160	1240	2450	2490
CH4		CH8 (MHZ)	1200	1280	2470	2510
PARAMETER	CONDITION		MIN.	TYP.	MAX.	UNIT.
Power Consumption	DC=12V		190	240	290	mA
Video Output Voltage	75 Ohm Impedance, RCA x 2			1		Vp-p
Audio Output Voltage	10k Ohm Impedance, RCA x 2			1	2	Vp-p
Sub Carrier Freq				6.5		MHz
Switch Time			0.5		10	Sec
Type Standard	NTSC/PAL					
Operating Temperature			-10		40	°C
Storage Temperature			-20		80	°C
Operating Humidity			20		80	%
Storage Humidity			10		80	%
Dimension			80x63x20			mm
Weight	Excluding SMA Connector		95			g

Standard Shipping Package

- AV Receiver & Switcher* 1
- SMA Type Dipole Antenna* 1
- Stereo Jack to RCA AV Output Cable* 1

Order Number

RXS-2460	2.4 GHz / 8CH Portable Receiver & Switcher
RX-1260	1.2 GHz / 8CH Portable Receiver & Switcher

Each Item Shipping With Cable & All Accessories.

TDS-240200 2.4GHz/0.2W AV Transmitter Device



- 2.4GHz Band frequency transmission
- Compact size module, RF output power (200mW)
- 4CH DIP switch selectable
- High Reliability/Linearity/AlGaAs/GaAs FET power amplifier module
- Using digital phase-Lock-Loop circuit w/o temperature drifting problem

● Specification

PARAMETER	CONDITION	MIN.	TYP.	MAX.	UNIT.
Transmission Frequency	CH1		2410		MHz
	CH2		2430		MHz
	CH3		2450		MHz
	CH4		2470		MHz
Transmission Power	50 Ohm Load CH1 Vcc=12V		24		dBm
Nominal Output Impedance					Ohm
Operating Voltage	Vcc		12		V
Supply Current	Vcc = 12V	210	250	260	mA
Video Input Voltage	75 Ohm Impedance		1		Vp-p
Audio Input Voltage	10k Ohm Impedance		2		Vp-p
Sub Carrier Freq			6.5		MHz
Operating Temp		-10		40	°C
Storage Temp		-40		80	°C
Operating Humidity		20		80	%
Storage Humidity		10		80	%
Dimension& Weight	Excluding SMA Connector	65x40x20mm 80g			

*Matching Receiver: RXS-2430 or RXS-2440

*Above specifications are subject to change without prior notice

● Standard Shipping Package

- 2.4GHz AV Transmitter*1
- SMA Type Dipole Antenna*1



Security and Intelligence Advising

TD-123000/ TD-243000 A/V Transmitter Device

Feature

- 1.2 & 2.4GHz Band frequency transmission option
- Compact size module, high output power (2Watt)
- High Reliability/Linearity/AlGaAs/GaAs FET power amplifier module built-in
- Using digital phase-Lock-Loop circuit without drifting problem under high temp. Occasion
- 4CH DIP switch selectable



Specification

Item Number	TD-243000	TD-123000
Frequency Band	2400MHz	1200MHz
Available Channel	4 Ch	
Output Power	2000 mW	
Trans. Range	500~1000 Meter	
Consumption Current	850 mA	
Audio Sub-Carrier	6.5MHz	5.5MHz
Operation Voltage	12 V	
Power Supply	12V / 2000mA	
Housing	Aluminum Alloy	
Weight (TX)	135 g	
Dimension (TX)	65x 60x 35 mm	
Attached Receiver	RX-2410	RX-1210

Mechanical Sketch

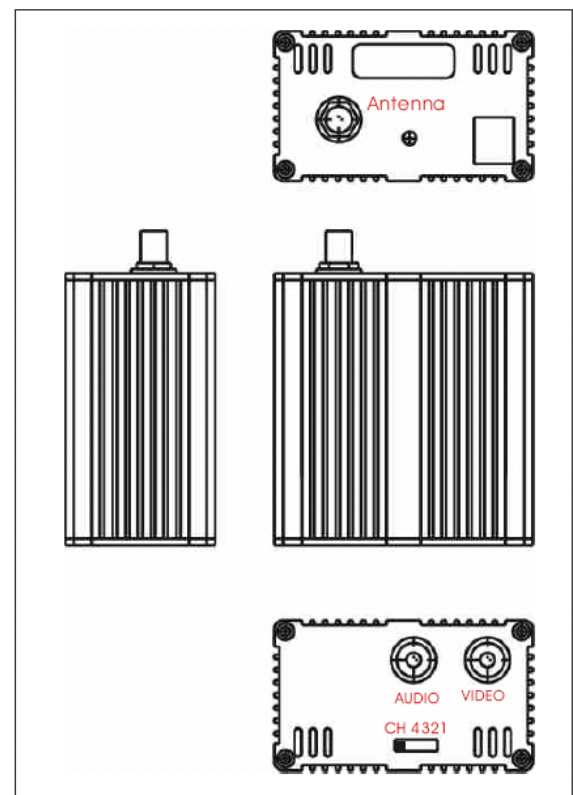

*Specification & appearance may be subjected to change without notice

Standard Shipping Package

- AV Transmitter Device *1
- Standard Dipole Antenna *1
- AV RCA Cable *1 & 2Amp / 12V Power Supply Unit *1



Security and Intelligence Advising

TDS-241800 2.4GHz 1W AV Transmitter / 8CH



- 2.4GHz Band frequency transmission
- Compact size module, high output power (1Watt)
- Highly integrated circuit /High power output (1Watt)
- 8CH DIP switch selectable
- High Reliability/Linearity/AlGaAs/GaAs FET power amplifier
- Using digital phase-Lock-Loop circuit w/o temperature drifting problem

● Specification

PARAMETER	CONDITION	MIN.	TYP.	MAX.	UNIT.
Transmission Frequency	CH1 CH5		2410	2370	MHz
	CH2 CH6		2430	2390	MHz
	CH3 CH7		2450	2490	MHz
	CH4 CH8		2470	2510	MHz
Transmission Power	50 Ohm Load CH1 Vcc=12V		30		dBm
Nominal Output Impedance			50		Ohm
Operating Voltage	Vcc	10.5	12	13	V
Supply Current	Vcc = 12V		450	500	mA
Video Input Voltage	75 Ohm Impedance		1		Vp-p
Audio Input Voltage	10k Ohm Impedance		1		Vp-p
Sub Carrier Freq			6.5		MHz
Operating Temp		-10		40	°C
Storage Temp		-40		80	°C
Operating Humidity		20		80	%
Storage Humidity		10		80	%
Dimension& Weight	Excluding SMA Connector	60X55X38mm		135 g	

*Matching Receiver: RXS-2440

*Above specifications are subject to change without prior notice

● Standard Shipping Package

- 2.4GHz AV Transmitter*1
- SMA Type Dipole Antenna*1 , AV Cable*1



Security and Intelligence Advising

RX-1260 / RX-2460

Feature

- 1.2 & 2.4GHz Band frequency receiving optional
- 5.5" Class A LCD Monitor Module Embedded
- 8-Channel Option A/V Receiver Device
- Auto/Manual switcher & AV input feature
- Producing clear audio affect & stable video affect
- Being able to hook up to 8 cameras and sending signals simultaneously



Specification

Item Number	RX-1260	RX-2460
Frequency Band	1200MHz	2400MHz
Available Channel	8 Ch	8 Ch
Sub-Carrier Freq.	5.5 Mhz	6.5 Mhz
Operating Voltage	DC 12V	
Consumption Current	240 mA	
Video Output	75 Ohm Impedance, RCA x 2	
Audio Output	10k Ohm Impedance, RCA x 2	
Power Adaptor	12V / 500mA	
Type Standard	NTSC /PAL	
Weight (TX)	95 g	
Dimension (TX)	80x 63x 20 mm	
Antenna Connector	De-tacheable SMA connector	

*Specification & appearance may be subjected to change without notice

Standard Shipping Accessories

- SMA Standard Type Dipole Antenna* 1
- Stereo Jack to RCA AV Output Cable* 1

Order Model Number

RX-2460CK	2.4 GHz / 8CH Receiver /w standard shipping accessories
RX-1260CK	1.2 GHz / 8CH Receiver /w Standard shipping accessories

Each Item Shipping With Cable & Antenna

TD-1218/ TD-2418 A/V Transmitter Device

Feature

- 1.2 & 2.4GHz Band frequency transmission option
- Much advanced Mag-aluminum alloy housing with better heat-sink feature & rugged construction
- High Reliability/Linearity/AlGaAs/GaAs FET power amplifier module built-in
- Using digital Phase-Lock-Loop circuit without drifting problem under high temp. occasion
- Built-in PDA type sticker for much convenient to adjust the CH select DIP switcher

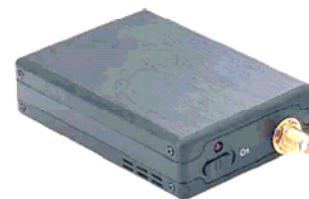

Specification

Item Number	TD-2418	TD-1218
Frequency Band	2400MHz	1200MHz
Available Channel	8 Ch	8 Ch
Trans. Range	1000 mW	1000 mW
Audio Sub-Carrier	6.5 Mhz	5.5MHz
Output Power	1000 mW	
Consumption Current	470 mA	
Operation Voltage	12 V	
Power Supply	12V / 500mA	
Housing	Mag-Aluminum Alloy	
Weight (TX)	60 g	
Dimension (TX)	80x 52x 18 mm	
Attached Receiver	RX-2460	RX-1260

Mechanical Sketch

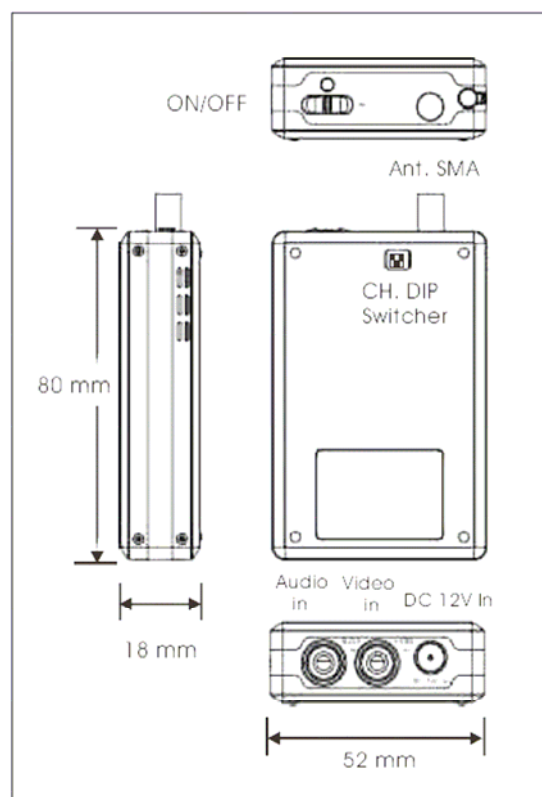

*Specification & appearance may be subjected to change without notice

Standard Shipping Package

- AV Transmitter Device *1
- Standard Dipole Antenna *1
- AV RCA Cable *1

TD-1205/ TD-2405 A/V Transmitter Device

Feature

- 1.2 & 2.4GHz Band frequency transmission option
- Much advanced Mag-aluminum alloy housing with better heat-sink feature & rugged construction
- High Reliability/Linearity/AlGaAs/GaAs FET power amplifier module built-in
- Using digital phase-Lock-Loop circuit without drifting problem under high temp. Occasion
- Built-in PDA type sticker for much convenient to adjust the CH select DIP switcher



Specification

Item Number	TD-2405	TD-1205
Frequency Band	2400MHz	1200MHz
Available Channel	8 Ch	3 Ch
Output Power	500 mW	500 mW
Trans. Range	400 Meter	
Consumption Current	350 mA	300 mA
Audio Sub-Carrier	6.5MHz	5.5 Mhz
Operation Voltage	5 V	
Power Supply	12V / 500mA	
Housing	Mag-Aluminum Alloy	
Weight (TX)	50 g	
Dimension (TX)	82x 52x 18 mm	
Attached Receiver	RXS-2460	RX-1260

*Specification & appearance may be subjected to change without notice

Standard Shipping Package

- AV Transmitter Device *1
- Standard Dipole Antenna *1
- AV RCA Cable *1



Security and Intelligence Advising

TD-1202/ TD-2402 A/V Transmitter Device

Feature

- 1.2 & 2.4GHz Band frequency transmission option
- Much advanced Mag-aluminum alloy housing with better heat-sink feature & rugged constructure
- High Reliability/Linearity/AlGaAs/GaAs FET power amplifier module built-in
- Using digital phase-Lock-Loop circuit without drifting problem under high temp. Occasion
- Built-in PDA type sticker for much convenient tilting the CH select DIP switcher



Specification

Item Number	TD-2402	TD-1202
Frequency Band	2400MHz	1200MHz
Available Channel	4 Ch	3 Ch
Output Power	200 mW	150 mW
Trans. Range	200 Meter	
Consumption Current	280 mA	180 mA
Audio Sub-Carrier	6.5 Mhz	5.5MHz
Operation Voltage	5 V	
Power Supply	12V / 500mA	
Housing	Mag-Aluminum Alloy	
Weight (TX)	50 g	
Dimension (TX)	80x 52x 18 mm	
Attached Receiver	RXS-2460	RX-1260

**Specification & appearance may be subjected to change without notice*

Standard Shipping Package

- AV Transmitter Device *1
- Standard Dipole Antenna *1
- AV RCA Cable *1

1.2/2.4 Ghz Portable A/V Transmitter & Receiver Kit

Feature

- Wired covert cameras double its value when work in conjunction with Portable Wireless A/V Transmitter & Receiver Kit and become wireless cameras.
- Vibration Alert when battery power is low
- Brilliant looking Mag-Aluminum alloy housing, great solution for heat sink
- Receiver utilizes 1800mAh ultra high capacity removable FUJI camcorder battery
- Single general stereo jack socket on transmitter for A/V signal output and power supply, hassle free on cable plugging
- Tx Use high capacity FUJI camcorder removable battery. Defective built-in battery problem is now a thing of past

Specification

Item Number	TB-2455	TB-1255
Frequency Band	2400MHz	1200MHz
Available Channel	8 Ch	3 Ch
Output Power	500 mW	500 mW
Trans. Range	300 Meter	500 Meter
Low-Batt. Alert	Yes, Vibration	
AC Charger	5 V / 2A	
DC Battery	3.6V / 1800mA	
Battery Charge Time	2 Hrs	
Battery Life Time	120 Munites	120 Munites
Weight (TX)	60 g	
Dimension (TX)	78x 66x 15 mm	
Attached Receiver	RX-2480B	RX-1280B

Mechanical Sketch

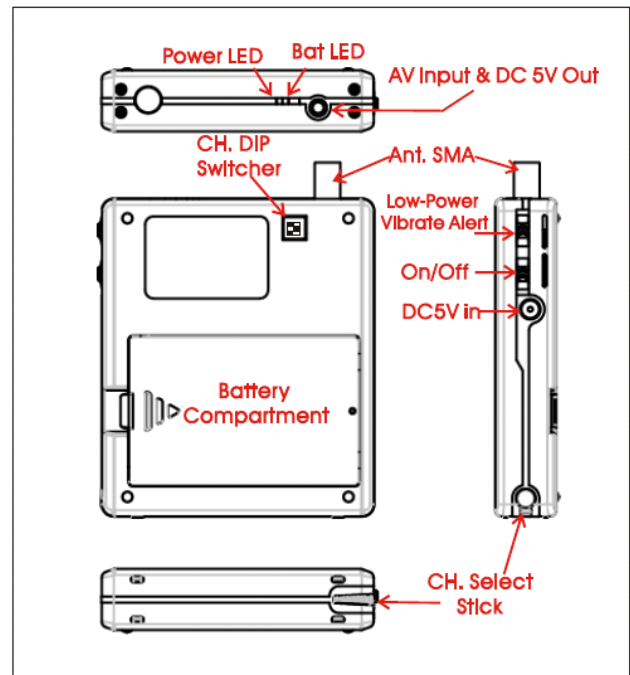

*Specification & appearance may be subjected to change without notice

Standard Full Package Kit & Order Model No.

TBR-2455CK



TB-2430
Portable Sender



RX-2480B
Portable Receiver

TBR-1255CK



TB-1230
Portable Sender



RX-1280B
Portable Receiver



Security and Intelligence Advising

1.2/2.4 Ghz Portable Switcher & Receiver

Feature

- Equipped built-in sticker for easier tilting the CH DIP switcher
- 8-Channel Option A/V Receiver Device
- Auto/Manual DIP switcher
- Life time could last 3.5 hours Using the built-in battery
- Low-Power alert via LED Indicator
- Compact & Rugged Meg-Aluminum Alloy cas Design
- Producing clear audio affect & stable video affect



Specification

Model Number	RX-2480B	RX-1280B
Frequency Band	2400MHz	1200MHz
Available Channel	8 Ch	8 Ch
Audio Sub-Carrier	6.5 Mhz	5.5 Mhz
Phase Logic Lock	Yes	Yes
AV Output	2.1 mm Stereo Jack	
AC Charger	5 V / 800mA	
DC Battery	FUJI Li-on 3.7V / 2200mA	
Battery Charge Time	3.5 Hrs	
Battery Life Time	3.5 Hrs	3.5 Hrs
Weight (TX)	135 g	
Dimension (TX)	110x 70x 20 mm	
Antenna Connector	De-tacheable SMA connector	

Mechanical Sketch

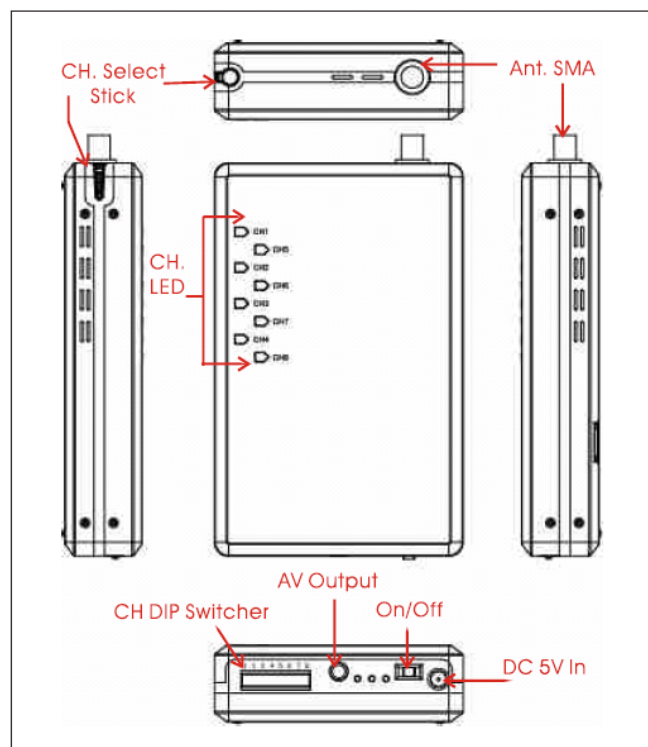

*Specification & appearance may be subjected to change without notice

Standard Shipping Accessories

- SMA Type Dipole Antenna*1
- Stereo Jack to RCA AV Output Cable*1
- Rechargeable Battery*1 & Charger*1

Order Model Number

RX-2480BCK 2.4 GHz / 8CH Receiver /w standard shipping accessories

RX-1280BCK 1.2 GHz / 8CH Receiver /w Standard shipping accessories

Each Item Shipping With Cable & Antenna



Security and Intelligence Advising

SC-0825 Wireless Camera Hunter

Features

- 2.5" Monitor Picture Receive Capability
- Intelligent panel & Smart key for simple use
- Long hours Monitoring Capability
- Manual / Auto operation modes offers simultaneously
- LCM indicator to show the status clearly
- Wide Frequency coverage
- Alarm Signal output exists to make the security application with more variety
- Aluminum-Mag Alloy Material Case / w Compact & Rugged Outlook Design
- Internal Disposable battery power & External Consistency AC adaptor exist

Application

- Counter-Surveillance device ideal for tracking down all of hidden & concealed wireless cameras abused more & more nowadays round us in every where.
- Normal wireless receiver with various Frequency bands.
- Testing equipment for RF engineer or installer use.

Standard Shipping Package

- Camera Hunter x 1
- Detachable SMA Antenna x 2
- External Power Adaptor (DC5V/750mA) x 1
- Alarm Terminal Cable x 1

Order Number



SC-0825 Various View

Specification

Scanning Range	900MHz~2520MHz
Operation Mode	Auto / Manual
Antenna Head	SMA (Detachable)
Battery Life-Time	3 Hours
Internal Power	AA Battery 1.5V x 4
External Power	DC 5V / 750mA
Video Display	2.5" colour TFT Monitor
Frequency Display	LCM
Auto Scan Mode	10~20 sec/cycle(L~H)
Manual Scan Mode	1 MHz/sec, 10 MHz/sec
Dimension	120(L) x 74(W) x 35(H)mm
Weight	240 g



Security and Intelligence Advising

MS-20 Cellular Type Wireless CCD Camera



- Totally Original Ericsson most popular Clam Phone Model Design From Outside look to Inside Battery Compartment
- 1/4 Panasonic DSP Color CCD Sensor Camera
- 450 TV lines 44,000 pixels, 1.0Lux F1.2
- Build in 4.3mm pinhole lens 78 Degree
- Unique Vibration Alert under low-Battery Status
- Phase Lock Loop (PLL) Circuitry Embedded
- Using Original Sony Ericsson Phone Battery & Charger

Specification

Item Number	MS20-240200				MS20-120200		
Channel	Ch1	Ch2	Ch3	Ch4	CH1	CH2	Ch3
Frequency (MHz)	2410	2430	2450	2470	1080	1120	1160
Output Power	150mW				150mW		
Trans. Range	50~150M				50~150M		
Mic. Sensitivity	-60 dbm						
AC Charger	AC100~120/220~240 to DC 4.9V / 450mA						
DC Power Supply	DC 3.6 / 770 mA Li-on Battery						
Bat. Charged Time	2 Hours						
Bat. Life Time	1 Hours				1 Hours		
Power Consumption	600mA				500mA		
Weight	90g (Include Battery)						
Dimension	98 x 46x 20 mm						

***FCC & CE Approval Item: MS20-240200**

Standard Shipping Package

- MS-20 Sony Ericsson Cellular Phone Type Camera * 1
- Hi-Capacity 770mA Li-on Rechargeable Battery*1
- Matched Receiver *1 & AC adaptor *1
- Battery Charger & Audio/Video Cable

Order Number

MS-20N120200CK	1.2GHz / NTSC Complete Kit
MS-20P120200CK	1.2GHz / PAL Complete Kit
MS-20N240200CK	2.4GHz / NTSC Complete Kit
MS-20P240200CK	2.4GHz / PAL Complete Kit



Security and Intelligence Advising

CL-10 Calculator Type Wireless CCD Camera



- Using the Original CASIO most Popular Calculator Model ,all Functions still remain to get a most concealed effect
- 1/4 SONY **DSP Color CCD** Sensor Camera
- 380 TV lines 32,000 pixels, 1.0Lux F1.2
- Build in 4.3mm pinhole lens 78 Degree
- Auto Electronic Shutter (AES) & Auto White Balance.
- Phase Lock Loop (PLL) Circuitry Embedded
- Complete Wireless Kit /w Receiver & Accessories

Specification

Item Number	CL10-240050			CL10-120100		
Channel	CH1	CH2	CH3	CH1	CH2	CH3
Frequency (MHz)	2410	2430	2450	1080	1120	1160
Output Power	50mW			100mW		
Trans. Range	30~150M			50~200M		
Mic. Sensitivity	60 dbm					
AC Adaptor (Rx)	AC100~120/220~240 to DC12V / 500mA					
DC Power	DC 9V / 595mA Alkaline Battery					
Bat. Life Time	2.5 Hours			2 Hours		
Power Consumption	170mA			220mA		
Weight	250g (Include Battery)					
Dimension	165 x 100 x 28 mm					

***FCC & CE Approval Item: CL10-240050**

Standard Shipping Package

- CL-10 Casio Calculator Type Camera * 1
- Energizer 9V Alkaline Battery*1
- Matched Receiver *1 & AC adaptor *1
- Audio/Video Cable

Order Number

CL-10N120100CK	1.2GHz / NTSC Complete Kit
CL-10P120100CK	1.2GHz / PAL Complete Kit
CL-10N240050CK	2.4GHz / NTSC Complete Kit
CL-10P240050CK	2.4GHz / PAL Complete Kit



Security and Intelligence Advising

CS-10 Cigarette Type Wireless CCD Camera

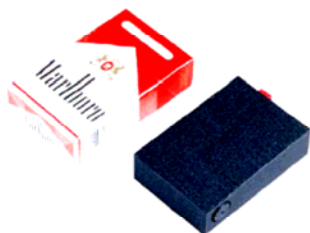

- International Standard Cigarette Pack Size Design
- 1/4 SONY DSP Color CCD Sensor Camera
- 380 TV lines 32,000 pixels, 1.0Lux F1.2
- Build in 4.3mm pinhole lens 78 Degree
- Auto Electronic Shutter (AES) & Auto White Balance.
- Phase Lock Loop (PLL) Circuitry Embedded
- Complete Wireless Kit /w Receiver & Accessories

Specification

Item Number	CS10-240050			CS10-120100		
Channel	CH1	CH2	CH3	CH1	CH2	CH3
Frequency (MHz)	2410	2430	2450	1080	1120	1160
Output Power	50mW			100mW		
Trans. Range	30~150M			50~200M		
Mic. Sensitivity	60 dbm					
AC Adaptor (Rx)	AC100~120/220~240 to DC12V / 500mA					
DC Power	DC 9V / 595mA Alkaline Battery					
Bat. Life Time	2.5 Hours			2 Hours		
Power Consumption	165mA			215mA		
Weight	100g (Include Battery)					
Dimension	80 x54x 32 mm					

***FCC & CE Approval Item: CS10-240050**

Standard Shipping Package

- CS-10 Cigarette Pack Type Camera * 1
- Energizer 9V Alkaline Battery*1
- Matched Receiver *1 & AC adaptor *1
- Audio/Video Cable

Order Number

CS-10N120100CK	1.2GHz / NTSC Complete Kit
CS-10P120100CK	1.2GHz / PAL Complete Kit
CS-10N240050CK	2.4GHz / NTSC Complete Kit
CS-10P240050CK	2.4GHz / PAL Complete Kit



Security and Intelligence Advising

BU-12 Button Wire Type CCD Camera

Feature

- Inter-changeable the front covert lens to a most efficient use
- High resolution & Super Fine resolution CCD sensor selectable for more critical demand application
- Complete power & cable accessories attached to offer output to more variety devices use
- Full range of our Wireless Kit accessory could be supported optionally

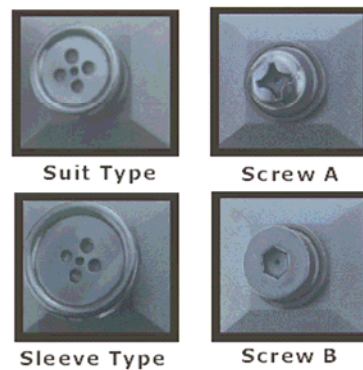

The standard attached four different covert

Specification

Model	Hi Resolution	Super-Hi Resolution
Resolution (TV Line)	350 TVL	450 TVL
Picture Element	510X492(NTSC)/ 500X582(PAL)	768X492(NTSC)/ 768X582(PAL)
CCD Image Sensor	1/4 Interline CCD	
Video System	NTSC /PAL	
S/N Ratio	48db(Min)/60bd(Typ)	
Minimum Illumination	0.2 Lux of F 1.2	
Electronic Shutter	1/60(1/50)-1/120,000	
Video Output	1.0V p-p Composite at 75 ohm	
Audio Output	2Vp-p(Max) 10kHz ohms Impedance	
MIC. Sensitivity	59dB +/- -3dB	
Lens	4.3mm	
Angel of View	80 Degree	
Power Supply	DC-12V	
Consumption Current	70mA	120mA
Dimension	26 (W) x 22(H) x 1(T) mm	

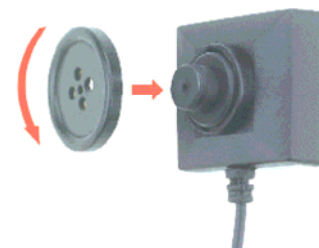

Easily changeable front covert



View Inside the Box

Standard Shipping Package



CCD Camera

Various Switchable Covert & Spares

Switching Cable

Battery Holder & Belt-Bag

Jewel Box Pack

Order Number

BU-12NCK Wire

Type BU-12 Button Camera Kit (NTSC)

BU-12PCK Wire

Type BU-12 Button Camera Kit (PAL)

Each Item Shipping With Cable & All Accessories



Security and Intelligence Advising

HB-10 Hand Bag Type wired CCD Camera

Feature

- Fine concealed design for totally unawareness from the outlook closely
- High resolution & Super Fine resolution CCD sensor selectable for more critical demand application
- Complete power & cable accessories attached to offer output to more variety devices use
- Full range of our Wireless Kit or miniature DVR device could work with optionally



Standard Shipping Package

Model	HI Resolution	Super-Hi Resolution
Resolution (TV Line)		450 TV Line
Picture Element	768X492(NTSC)/ 768X582(PAL)	
CCD Image Sensor	1/4 Interline CCD	
Video System	NTSC /PAL	
S/N Ratio	48db(Min)/60bd(Typ)	
Minimum Illumination	0.2 Lux of F 1.2	
Electronic Shutter	1/60(1/50)-1/120,000	
A.G.C.	+18dB Max.	
Video Output	1.0V p-p Composite at 75 ohm	
Audio Output	2Vp-p(Max) 10kHz ohms Impedance	
MIC. Sensitivity	59dB +/- -3dB	
Lens	4.3mm	
Angel of View	80 Degree	
Power Supply	DC 9~12V	
Consumption Current	120mA	

Standard Shipping Package

- HB-10 Hand Bag Type Camera * 1
- Switching AV & Power Cable *1
- 9V Battery compartment holder *1

Optional Device

- 1.2GHz or 2.4GHz Wireless Kit
- Miniature AV recording device



Security and Intelligence Advising

ER-10 Earphone Type Wired CCD Camera

Feature

- Fine concealed design for totally unawareness from the outlook closely
- High resolution & Super Fine resolution CCD sensor selectable for more critical demand application
- Complete power & cable accessories attached to offer output to more variety devices use
- Full range of our Wireless Kit or miniature DVR device could work with optionally



Specification

Model	Hi Resolution	Super-Hi Resolution
Resolution (TV Line)	450 TV Line	
Picture Element	768X492(NTSC)/ 768X582(PAL)	
CCD Image Sensor	1/4 Interline CCD	
Video System	NTSC /PAL	
S/N Ratio	48db(Min)/60bd(Typ)	
Minimum Illumination	0.2 Lux of F 1.2	
Electronic Shutter	1/60(1/50)-1/120,000	
A.G.C.	+18dB Max.	
Video Output	1.0V p-p Composite at 75 ohm	
Audio Output	2Vp-p(Max) 10kHz ohms Impedance	
MIC. Sensitivity	59dB +/- -3dB	
Lens	4.3mm	
Angel of View	80 Degree	
Power Supply	DC 9~12V	
Consumption Current	120mA	

Standard Shipping Package

- ER-10 Earphone Type CCD Camera *1
- Switching AV & Power Cable *1
- 9V Battery compartment holder *1



Optional Device

- 1.2GHz or 2.4GHz Wireless Kit
- Miniature AV recording device



Security and Intelligence Advising

NT-10 Necktie Type wired CCD Camera

Feature

- Fine concealed design for totally unawareness from the outlook closely
- High resolution & Super Fine resolution CCD sensor selectable for more critical demand application
- Complete power & cable accessories attached to offer output to more variety devices use
- Full range of our Wireless Kit or miniature DVR device could work with optionally



Specification

Model	HI Resolution	Super-Hi Resolution
Resolution (TV Line)	450 TV Line	
Picture Element	768X492(NTSC)/ 768X582(PAL)	
CCD Image Sensor	1/4 Interline CCD	
Video System	NTSC /PAL	
S/N Ratio	48db(Min)/60bd(Typ)	
Minimum Illumination	0.2 Lux of F 1.2	
Electronic Shutter	1/60(1/50)-1/120,000	
A.G.C.	+18dB Max.	
Video Output	1.0V p-p Composite at 75 ohm	
Audio Output	2Vp-p(Max) 10kHz ohms Impedance	
MIC. Sensitivity	59dB +/- -3dB	
Lens	4.3mm	
Angel of View	80 Degree	
Power Supply	DC 9~12V	
Consumption Current	120mA	

Standard Shipping Package

- NT-10 Necktie Type CCD Camera *1
- Switching AV & Power Cable *1
- 9V Battery compartment holder *1

Optional Device

- 1.2GHz or 2.4GHz Wireless Kit
- Miniature AV recording device



Security and Intelligence Advising

CP-10 Men's Cap Type Wired CCD Camera

Feature

- Fine concealed design for totally unawareness from the outlook closely
- High resolution & Super Fine resolution CCD sensor selectable for more critical demand application
- Complete power & cable accessories attached to offer output to more variety devices use
- Full range of our Wireless Kit or miniature DVR device could work with optionally



Specification

Model	HI Resolution	Super-Hi Resolution
Resolution (TV Line)	450 TV Line	
Picture Element	768X492(NTSC)/ 768X582(PAL)	
CCD Image Sensor	1/4 Interline CCD	
Video System	NTSC /PAL	
S/N Ratio	48db(Min)/60bd(Typ)	
Minimum Illumination	0.2 Lux of F 1.2	
Electronic Shutter	1/60(1/50)-1/120,000	
A.G.C.	+18dB Max.	
Video Output	1.0V p-p Composite at 75 ohm	
Audio Output	2Vp-p(Max) 10kHz ohms Impedance	
MIC. Sensitivity	59dB +/- -3dB	
Lens	4.3mm	
Angel of View	80 Degree	
Power Supply	DC 9~12V	
Consumption Current	120mA	

Standard Shipping Package

- CP-10 Necktie Type CCD Camera *1
- Switching AV & Power Cable *1
- 9V Battery compartment holder *1

Optional Device

- 1.2GHz or 2.4GHz Wireless Kit
- Miniature AV recording device



Security and Intelligence Advising

BS-10 Booklet Type wired CCD Camera

Feature

- Fine concealed design for totally unawareness from the outlook closely
- High resolution & Super Fine resolution CCD sensor selectable for more critical demand application
- Complete power & cable accessories attached to offer output to more variety devices use
- Full range of our Wireless Kit or miniature DVR device could work with optionally

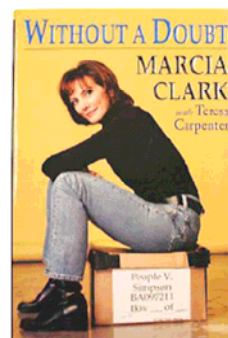

Standard Shipping Package

Model	HI Resolution	Super-HI Resolution
Resolution (TV Line)		450 TV Line
Picture Element	768X492(NTSC)/ 768X582(PAL)	
CCD Image Sensor		1/4 Interline CCD
Video System		NTSC /PAL
S/N Ratio		48db(Min)/60bd(Typ)
Minimum Illumination		0.2 Lux of F 1.2
Electronic Shutter		1/60(1/50)-1/120,000
A.G.C.		+18dB Max.
Video Output		1.0V p-p Composite at 75 ohm
Audio Output		2Vp-p(Max) 10kHz ohms Impedance
MIC. Sensitivity		59dB +/- -3dB
Lens		4.3mm
Angel of View		80 Degree
Power Supply		DC 9~12V
Consumption Current		120mA

Standard Shipping Package

- BS-10 Booklet Type Camera * 1 /w Dummy Booklet * 1
- Switching AV & Power Cable *1
- 9V Battery compartment holder *1

Optional Device

- 1.2GHz or 2.4GHz Wireless Kit
- Miniature AV recording device



Security and Intelligence Advising

BH-10 Broach Type wired CCD Camera

Feature

- Fine concealed design for totally unawareness from the outlook closely
- High resolution & Super Fine resolution CCD sensor selectable for more critical demand application
- Complete power & cable accessories attached to offer output to more variety devices use
- Full range of our Wireless Kit or miniature DVR device could work with optionally



Standard Shipping Package

Model	HI Resolution	Super-Hi Resolution
Resolution (TV Line)	450 TV Line	
Picture Element	768X492(NTSC)/ 768X582(PAL)	
CCD Image Sensor	1/4 Interline CCD	
Video System	NTSC /PAL	
S/N Ratio	48db(Min)/60bd(Typ)	
Minimum Illumination	0.2 Lux of F 1.2	
Electronic Shutter	1/60(1/50)-1/120,000	
A.G.C.	+18dB Max.	
Video Output	1.0V p-p Composite at 75 ohm	
Audio Output	2Vp-p(Max) 10kHz ohms Impedance	
MIC. Sensitivity	59dB +/- -3dB	
Lens	4.3mm	
Angel of View	80 Degree	
Power Supply	DC 9~12V	
Consumption Current	120mA	

Standard Shipping Package

- BH-10 Broach Type Camera * 1
- Switching AV & Power Cable *1
- 9V Battery compartment holder *1

Optional Device

- 1.2GHz or 2.4GHz Wireless Kit
- Miniature AV recording device



Security and Intelligence Advising

SS-20 Snake Type wired CCD Camera

Feature

- Fine concealed design for totally unawareness from the outlook closely
- High resolution & Super Fine resolution CCD sensor selectable for more critical demand application
- Complete power & cable accessories attached to offer output to more variety devices use
- Full range of our Wireless Kit or miniature DVR device could work with optionally



Standard Shipping Package

Item Number	SS-20NCK	SS-20PCK
Video System	NTSC	
Picture Element	(H)768x(V)492	(H)768x(V)582
Resolution (H)	450 TV Line	
CCD Image Sensor	1/4 Interline CCD	
S/N Ratio	48 db (MIN)	
MIN Illumination	0.2 Lux / F1.2	
Electronic Shutter	1/60~1/120,000	1/50~1/120,000
A.G.C.	+18 dB MAX	
Video Output	1.0Vp-p Composite at 75 ohm	
Audio Output	2Vp-p(MAX) 10KHz ohms Impedance	
MIC Sensitivity	59 dB +/- 13 dB	
Lens	4.3 mm	
Angel of View	80 Degree	
Power Supply Voltage	5V +/- 0.5V	
Power Supply Current	250mA	
Dimension(Incl Lens)	12(W) x 12(H) x 19(T) mm	
Weight	30g	

*Specification & appearance may be subjected to change without notice

Standard Shipping Accessories

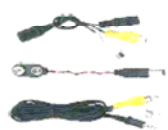

Switching Cable



Battery Holder & Belt-Bag



Jewel Box Pack



Profile of the Main Part

Optional Device

- 1.2GHz or 2.4GHz Wireless Kit
- Miniature AV recording device



Security and Intelligence Advising

ER-14 Tactical Helmet Type Wired CCD Camera

Feature

- Fine integrated & compact regular headset outlook design with concealment & convenience feature
- Super fine picture quality with high resolution CCD sensor for demanding surveillance application.
- Powered directly from our PVR series or the battery box in standard kit. Two solutions for variety scenarios.
- When works with any of our PVR and Wireless Kit a battery box is not needed.



Specification

Item Number	ER-14NCK	ER-14PCK
Video System	NTSC	PAL
Number of Pixel	(H)768x(V)492	(H)768x(V)582
Resolution (H)	450 TV Line	
CCD Image Sensor	1/4 Interline CCD	
S/N Ratio	48 db (MIN)	
MIN Illumination	0.2 Lux / F1.2	
Electronic Shutter	1/60~1/120,000	1/50~1/120,000
A.G.C.	+18 dB MAX	
Video Output	1.0Vp-p Composite at 75 ohm	
Audio Output	2Vp-p(MAX) 10KHz ohms Impedance	
MIC Sensitivity	59 dB +/-13 dB	
Lens	4.3 mm	
Angel of View	80 Degree	
Power Supply Voltage	5V +/-0.5V	
Power Supply Current	250mA	
Dimension(Incl Lens)	29(W) x 25(H) x 19(T) mm	
Weight	30g	

*Specification & appearance may be subjected to change without notice

Application

- Traffic or Patrol Police— record any offense taking place on scene.
- SWAT team— recording during crack down or rescues missions.
- Security guard—record the scene when on duty.
- Education to use— recording the Lecture & tutorial for review & reference.
- Out door excise— record all kind of outdoor activities.



Patrol police

Security Guard

Standard Shipping Accessories

Switching
Cable

9V Battery
Holder

Standard
Package



Training course



SWAT team

Optional Device

- 1.2GHz or 2.4GHz Wireless Kit
- Miniature AV recording device



Security and Intelligence Advising

ER-12 Headset Type Wired CCD Camera

Feature

- Fine integrated & compact regular headset outlook design with concealment & convenience feature
- Super Fine quality with High resolution CCD sensor for more critical surveillance demand application
- Complete power & cable accessories attached to offer output to more variety devices use
- Full range of our Wireless Kit or miniature PVR device could work with optionally



Specification

Item Number	ER-12NCK	ER-12PCK
Video System	NTSC	PAL
Number of Pixel	(H)768x(V)492	(H)768x(V)582
Resolution (H)	450 TV Line	
CCD Image Sensor	1/4 Interline CCD	
S/N Ratio	48 db (MIN)	
MIN Illumination	0.2 Lux / F1.2	
Electronic Shutter	1/60~1/120,000	1/50~1/120,000
A.G.C.	+18 dB MAX	
Video Output	1.0Vp-p Composite at 75 ohm	
Audio Output	2Vp-p(MAX) 10KHz ohms Impedance	
MIC Sensitivity	59 dB +/- 13 dB	
Lens	4.3 mm	
Angel of View	80 Degree	
Power Supply Voltage	5V +/- 0.5V	
Power Supply Current	250mA	
Dimension(Incl Lens)	29(W) x 25(H) x 19(T) mm	
Weight	30g	

*Specification & appearance may be subjected to change without notice

Application

- Traffic or Patrol Police— recording all illegal activity
- SWAT team— recording during the attack or rescue mission
- Door-Guard/Bodyguard— recording the scene during the urgent condition
- Education to use— recording the lecture for review & practice
- Out door excise— recording any kind of sports or outdoor activities



Patrol police



Bodyguard

Standard Shipping Accessories



Switching Cable



Battery Holder



Jewel Box Pack



Training course



SWAT team

Optional Device

- 1.2GHz or 2.4GHz Wireless Kit
- Miniature AV recording device



Security and Intelligence Advising

Stand Alon Fixed Bug Detection System

'The Man Who Almost Broke The Bank'

The real threat to the Casino is the introduction of Bluetooth devices, wireless video transmitters that can be used with PDAs and mobile phones with video. Using this type of equipment requires the gamer to have a partner, typically in the same room, who can evaluate the table and make suggestions to his or her partner to increase the odds of winning. This is known as advantage gaming and until now has been impossible to detect.



Despite this sophistication, all these devices must transmit signals from the player to the partner and back. The detection of these signals is our business.

Casino Guard is a new concept, offering 24 hour, on-line protection of the gaming rooms. Whether you are being 'attacked' by radio listening devices, Mobile Phones (GSM, 3G), Bluetooth and WiFi, you can be confident that the integrity of your gaming floors remains intact.

Real time protection means that detection will be made the instant the threat arises, enabling you to take appropriate action before any serious losses are incurred.

User Benefits

- Simple operation
- Detects all analogue and digital transmitters
- Integrated sensors optimises detection of suspicious devices
- Real time monitoring
- Signals can be filtered out, making it easier to interpret results
- User friendly set up
- Network compatible
- 24/7 protection
- Battery back up in case of power failure
- Alarm graphics enables quick identification of gaming area under threat

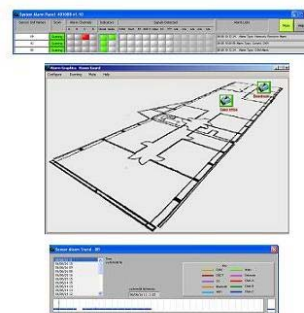
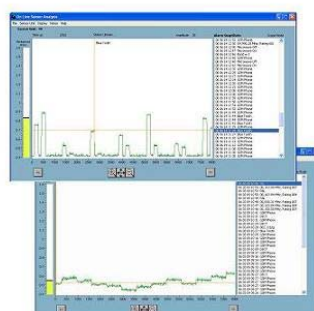
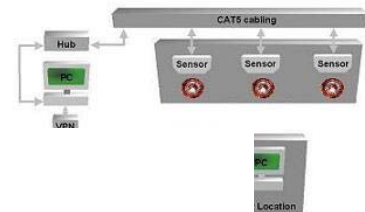



Security and Intelligence Advising

Multi Function Detector

For the first time four key methods of detection have been integrated into one easy-to-use unit designed to provide anyone with the ability to detect and locate electronic eavesdropping devices.

Just as protecting your computer requires action against different threats such as viruses and hacking, different types of electronic eavesdropping device require different methods of detection

Until now this has meant using several different types of equipment, each specializing in a different threat

Integrating four main detection methods, the Multi Function Detector provides the most comprehensive search tool available.

As well as addressing the various eavesdropping threats the combined sensors work together to enhance the search capability, providing a more complete picture of the search environment

Light and portable with an excellent battery life, the Multi Function Detector is easily transported and can be used with minimal training and is the ideal tool for securing today's business meeting.



Multi Function Detector – User Benefits:

- Designed for non-technical users
- Integrated use of sensors optimizes detection of devices
- Simplified presentation of complex information
- User-friendly touch-screen controls
- Clear indication of targets
- Simultaneous sensor sweep significantly reduce search time
- Cost-effective solution for bug detection
- Ergonomic light-weight design for comfortable operation
- Compact for easy transportation
- Integrated scanning receiver, non-linear junction detector, broadband receiver and metal detector.

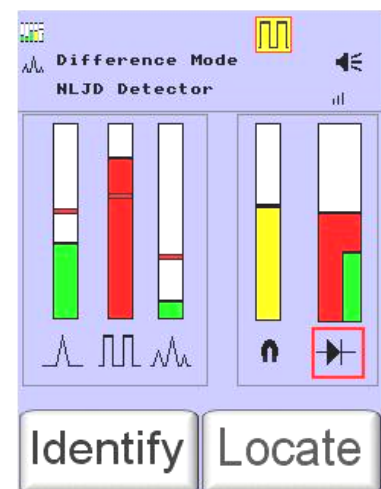



Security and Intelligence Advising

Counter Surveillance Receiver

When searching for active RF transmitter listening devices, speed is essential. If important meeting areas are under threat from electronic eavesdropping, minutes or even seconds could potentially be worth tens of thousands of pounds to an eavesdropper.

The detection and location of illicit RF transmissions requires swift and silent action to identify and locate listening devices on the Radio Spectrum without alerting potential eavesdroppers to what is happening



Our Counter Surveillance Receiver makes the detection, identification and location of covert radio transmitters quicker and easier than ever before. Imagine how long it would take to manually tune a radio into every station on the FM bandwidth to identify what was transmitting at each frequency. With our Counter Surveillance Receiver you can not only cover the whole FM bandwidth, but a 500 times wider bandwidth, all in less than 5 seconds. The Global Spectral Analysis Software adds a further dimension to identifying listening devices. The Counter Surveillance Receiver can be controlled remotely via telecommunication networks. Data can be saved directly to disk for further analysis; allowing multiple scan comparisons easily identifying any new and unusual bursts in activity. Compact and portable, the Counter Surveillance Receiver is easily transported and can be desk-mounted for continuous monitoring during meetings.

Counter Surveillance Receiver – User Benefits

- Quickly identifies and locates active RF transmitters
- Simplified presentation of complex information
- Controllable externally via telecommunication networks to perform scans as required from any location
- Compact for easy transportation
- Cable checking function allows operator to check telephone and mains cables for listening devices
- Records identified legitimate signals, speeding up subsequent scans
- Desk-mountable to provide continuous monitoring during meeting
- Timer function allows regular scans of an area to be recorded for later analysis
- Graphic software spectral analysis for easy identification of suspicious devices

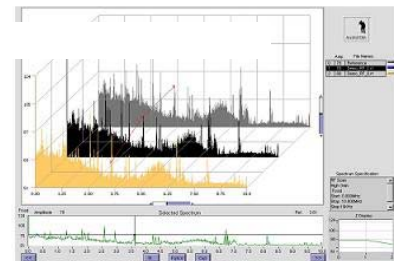



Security and Intelligence Advising

JAMMER – JM-EA

The JM-EA has been designed for blocking cellular networks and all kinds of cellular standards to fit the demand for world wide indoor use.

The JM-EA transmits a noise signal which cut-off all cellular communication between mobile phone and cellular cells. The blocking range is up to 20m, depending on environmental conditions and unit configuration.

The unit can block up to five bands, with power up to 2W per band. The jamming radius depends on the signal strength in the given area, all mobiles phones in the surrounding of the JM-EA will not be able to receive, dial or getting SMS messages.

When the JM-EA is working the mobile phone inside the jamming radius will indicate – NO SERVICE.

The unit is simple to use and carry, it has internal rechargeable batteries and antennas & have a plastic housing that makes it light and perfect to personal use.

Specifications

Power	Up to 2 Watt per band
Antenna Types	Internal
Control	On / off switch
Indicators	<ul style="list-style-type: none">• On / Off• Charge• Low Battery
Power supply	Rechargeable batteries / 90-264 V AC, CE, UL
Operation temperatur	-20° C - 60° C.
Total weight	Approx. 1.00kg
Size	22x14x4 cm
Case Housing	Plastic case
Warranty	12 months

Frequency Band

AMPS 850 Mhz – 925Mhz
CDMA 850 Mhz – 925 Mhz
L-GSM 925Mhz – 960Mhz
EDGE / H-GSM 1805Mhz-1880Mhz
PCS 1930Mhz-1990Mhz
UMTS(3G) 2110Mhz – 2170Mhz
WLAN 2400Mhz-2500Mhz





Security and Intelligence Advising

JAMMER – JM-LI

The JM-LI has been designed for blocking cellular networks and all kinds of cellular standards to fit the demand for world wide indoor use.

The JM-LI transmits a noise signal which cut-off all cellular communication between mobile phone and cellular cells. The blocking range is up to 20m, depending on environmental conditions and unit configuration.

The unit can block up to five bands, with power up to 2W per band. The jamming radius depends on the signal strength in the given area, all mobiles phones in the surrounding of the JM-LI will not be able to receive, dial or getting SMS messages. Haboleshet Spy Shop Ltd offers different kind of antennas depending on customer's application and needs.

When the JM-LI is working the mobile phone inside the jamming radius will indicate – NO SERVICE.

This device is stationary, it can be placed on a table or can be mounted on a wall which makes this product perfect solution for office use.

Specifications

Power	Up to 2Watt per band
Antenna Types	External Omni directional
Control Indicators	On / off switch remote control (optional)
Power supply	External AC adapter 90-240V AC, 50/60 Hz, CE, UL
Operation temperatur	-20° C - 60° C.
Total weight	Approx 1kg
Size	18x15x4cm
Case Housing	Metal Case
Optional	Remote control
Warranty	12 months

Frequency Band

AMPS 850 Mhz – 925Mhz
CDMA 850 Mhz – 925 Mhz
L-GSM 925Mhz – 960Mhz
EDGE / H-GSM 1805Mhz-1880Mhz
PCS 1930Mhz-1990Mhz
UMTS(3G) 2110Mhz – 2170Mhz
WLAN 2400Mhz-2500Mhz





Security and Intelligence Advising

JAMMER – JM-TI

The JM-TI has been designed for blocking cellular networks and all kinds of cellular standards to fit the demand for world wide indoor use.

The JM-TI transmits a noise signal which cut-off all cellular communication between mobile phone and cellular cells. The blocking range is up to 100m, depending on environmental conditions and unit configuration.

The unit can block up to 5 bands, with power up to 8W –15W per band. The jamming radius depends on the signal strength in the given area, all mobiles phones in the surrounding of the JM-TI will not be able to receive, dial or getting SMS messages.

Haboleshet Spy Shop Ltd offers different kind of antennas depending on customer's application and needs.

When the JM-TI is working the mobile phone inside the jamming radius will indicate – NO SERVICE.

Specifications

Minimum Power	8-15 Watt per band
Antenna Types	External / Patch
Control Indicators	On / off switch remote control (optional)
Power supply	External AC adapter 90-264V AC, 50/60 Hz, CE, UL
Operation temperatur	-20° C - 60° C.
Total weight App.:	4.5 kg
Size	43x26x13cm
Case Housing	Metal Case, cooling fan
Optional	Remote control
Warranty	12 months

Frequency Band

AMPS 850 Mhz – 925Mhz
CDMA 850 Mhz – 925 Mhz
L-GSM 925Mhz – 960Mhz
EDGE / H-GSM 1805Mhz-1880Mhz
PCS 1930Mhz-1990Mhz
UMTS(3G) 2110Mhz – 2170Mhz
WLAN 2400Mhz-2500Mhz





Security and Intelligence Advising

JAMMER – JM-JA

The JM-JA has been designed for blocking cellular networks and all kinds of cellular standards to fit the demand for world wide indoor use.

The JM-JA transmits a noise signal which cut-off all cellular communication between mobile phone and cellular cells. The blocking range is up to 100m, depending on environmental conditions and unit configuration.

The unit can block up to 4 bands, with power up to 50W –100W per band. The jamming radius depends on the signal strength in the given area, all mobiles phones in the surrounding of the JM-JA will not be able to receive, dial or getting SMS messages.

Haboleshet Spy Shop Ltd offers different kind of antennas depending on customer's application and needs.

When the JM-JA is working the mobile phone inside the jamming radius will indicate – NO SERVICE.

Specifications

Power	50-100 Watt per band
Antenna Types	External Omni
Control Indicators	On / off switch remote control (optional)
Power supply	90-264V AC, 50/60 Hz, CE, UL
Operation temperatur	-20° C - 60° C.
Total weight App.:	9 kg
Size	43x26x13cm
Case Housing	19 inch metal mount, 3U, cooling fan
Optional	Adjustable blocking range Remote control
Warranty	12 months

Frequency Band

AMPS 850 Mhz – 925Mhz
CDMA 850 Mhz – 925 Mhz
L-GSM 925Mhz – 960Mhz
EDGE / H-GSM 1805Mhz-1880Mhz
PCS 1930Mhz-1990Mhz
UMTS(3G) 2110Mhz – 2170Mhz
WLAN 2400Mhz-2500Mhz





Security and Intelligence Advising

JAMMER – JM-RH

The JM-RH has been designed for blocking cellular networks and all kinds of cellular standards to fit the demand for world wide indoor use.

The JM-RH transmits a noise signal which cut-off all cellular communication between mobile phone and cellular cells. The blocking range is up to 30m, depending on environmental conditions and unit configuration.

The unit can block up to 4 bands, with power up to 4W –8W per band. The jamming radius depends on the signal strength in the given area, all mobiles phones in the surrounding of the JM-RH will not be able to receive, dial or getting SMS messages. Haboleshet Spy Shop Ltd offers different kind of antennas depending on customer's application and needs.

When the JM-RH is working the mobile phone inside the jamming radius will indicate – NO SERVICE.

This device is stationary, it can be placed on a table or can be mounted on a wall which makes this product perfect solution for office use.

Specifications

Power	4-8 Watt per band
Antenna Types	External - Patch / Omni
Control Indicators	On / off switch remote control (optional)
Power supply	External AC adapter 90-264V AC, 50/60 Hz, CE, UL
Operation temperatur	-20° C - 60° C.
Total weight App.:	3 kg
Size	26x18x11cm
Case Housing	Metal Case, cooling fan
Optional	Adjustable blocking range Remote control
Warranty	12 months

Frequency Band

AMPS 850 Mhz – 925Mhz
CDMA 850 Mhz – 925 Mhz
L-GSM 925Mhz – 960Mhz
EDGE / H-GSM 1805Mhz-1880Mhz
PCS 1930Mhz-1990Mhz
UMTS(3G) 2110Mhz – 2170Mhz
WLAN 2400Mhz-2500Mhz





Security and Intelligence Advising

JAMMER – JM-HA

The JM-HA has been designed for blocking cellular networks and all kinds of cellular standards to fit the demand for world wide indoor use.

The JM-HA transmits a noise signal which cut-off all cellular communication between mobile phone and cellular cells. The blocking range is up to 100m, depending on environmental conditions and unit configuration.

The unit can block up to 5 bands, with power up to 5W –15W per band. The jamming radius depends on the signal strength in the given area, all mobiles phones in the surrounding of the JM-HA will not be able to receive, dial or getting SMS messages.

Haboleshet Spy Shop Ltd offers different kind of antennas depending on customer's application and needs.

When the JM-HA is working the mobile phone inside the jamming radius will indicate – NO SERVICE.

Specifications

Power	5-15 Watt per band
Antenna Types	Internal (connectors for external antennas patch/Omni)
Control	On / off switch remote control (optional)
Indicators	<ul style="list-style-type: none">• On / Off• Charge• Low Battery
Power supply	<ul style="list-style-type: none">• Rechargeable batteries, up to 2 hours• 12/24 V DC and/or 90-264 V AC
Operation temperatur	-20° C - 60° C.
Total weight App.:	11kg
Size	45x32x18cm
Case Housing	Adjustable blocking range Remote control
Warranty	12 months

Frequency Band

AMPS 850 Mhz – 925Mhz
CDMA 850 Mhz – 925 Mhz
L-GSM 925Mhz – 960Mhz
EDGE / H-GSM 1805Mhz-1880Mhz
PCS 1930Mhz-1990Mhz
UMTS(3G) 2110Mhz – 2170Mhz
WLAN 2400Mhz-2500Mhz





Security and Intelligence Advising

JAMMER – JM-PA

The JM-PA has been designed for blocking cellular networks and all kinds of cellular standards to fit the demand for world wide indoor use.

The JM-PA transmits a noise signal which cut-off all cellular communication between mobile phone and cellular cells. The blocking range is up to 200m, depending on environmental conditions and unit configuration.

The unit can block up to five bands, with power up to 15W –50W per band. The jamming radius depends on the signal strength in the given area, all mobiles phones in the surrounding of the JM-PA will not be able to receive, dial or getting SMS messages.

Haboleshet Spy Shop Ltd offers different kind of antennas depending on customer's application and needs.

When the JM-PA is working the mobile phone inside the jamming radius will indicate – NO SERVICE.

This device is stationary, it can be placed on a table or can be mounted on a wall which makes this product perfect solution for office use.

Specifications

Power	15-50 Watt per band
Antenna Types	External Omni
Control Indicators	On / off switch remote control (optional)
Operating Voltage	90-264V AC, 50/60 Hz, CE, UL
Operation temperatur	-20° C - 60° C.
Total weight App.:	7 kg
Size	43x26x13cm
Case Housing	19 inch rack mount, 2U, cooling fan
Optional	<ul style="list-style-type: none">• Adjustable blocking range• Remote control
Warranty	12 months

Frequency Band

AMPS 850 Mhz – 925Mhz
CDMA 850 Mhz – 925 Mhz
L-GSM 925Mhz – 960Mhz
EDGE / H-GSM 1805Mhz-1880Mhz
PCS 1930Mhz-1990Mhz
UMTS(3G) 2110Mhz – 2170Mhz
WLAN 2400Mhz-2500Mhz





Security and Intelligence Advising

HSS-40 - UHF ANALOG - USB CABLE TRANSMITTER

Battery life is always an issue with continuous investigation. Using USB as a power source, HSS-40 helps users to accomplish their purposes without worrying about battery.

The other pro is that the HSS-40 is fully functional as a USB2.0 cable. It means that a transmitter can be set as a replacement for an connecting cable of ordinary USB devices such as printer, CD drive or external hard drive.

If there is no peripherals around, simply plug HSS-40 to a computer and put the other end wherever you want and it still works as a battery-less transmitter. All you need is an available USB port of a computer that is turned on and running.

Specification:

SIZE... Cable Length 1.5m

WEIGHT... 77g

POWER SUPPLY... USB bus power

BATTERY LIFE... N/A

AVAILABLE CHANNELS... UHF-A, UHF-B

MIC EFFECTIVE RANGE... 15m from circle point



HSS-250 UHF ANALOG - PEN TRANSMITTER

High quality pen Audio Tx, innocent eavesdropping professional tool. put it in your pocket or just place it inside a room or an office.

It has smart innocent design & you can use it to write.

High reliability, high sound quality, long range Tx makes the HSS-250 a great tool for gathering intelligence.

Specification:

SIZE... Ø14 (15) x 124mm

WEIGHT... 28g (with batteries)

POWER SUPPLY... Alkaline button battery LR-44 (1.5V) x 3pcs

BATTERY LIFE... Approx. 40-50 hours

AVAILABLE CHANNELS... UHF-A, UHF-B

MIC EFFECTIVE RANGE... 10m from circle point

Tx RANGE Approx 150m (in side a city)





Security and Intelligence Advising

HSS 700 UHF ANALOG MODULAR TELEPHONE TRANSMITTER

HSS 700 provides continues conversation monitoring on targeted telephone, the transmitter takes its power directly from the line it self so no external power needed.

Specification:

SIZE... 16.5 x 22 x 37mm / Modular cable 10cm

WEIGHT... 9g

POWER SUPPLY... Telephone line current. No battery required.

AVAILABLE CHANNELS... UHF-A, UHF-B, UHF-C

INSTALLATION... Bridge connection between wall jack and telephone.



HSS-203 UHF ANALOG - CALCULATOR TRANSMITTER

High quality calculator Audio Tx, innocent eavesdropping professional tool. One of the best sellers products, completely camouflaged internal design, looks very natural when left in the office.

High ratability, high sound quality, long range Tx makes the HSS-203 a great tool for gathering inelegance.

Specification:

SIZE... 175.5 x 107 x 29.3mm

WEIGHT... 166g

POWER SUPPLY... Lithium button battery CR-2032(3V) x 1

BATTERY LIFE... Approx. 7h (CR-2032 x 1)

AVAILABLE CHANNELS... UHF-A, UHF-B, UHF-C

MIC EFFECTIVE RANGE... 15m from circle point

Tx RANGE Approx 150m (in side a city)





Security and Intelligence Advising

HSS-400 UHF ANALOG - UMBRELLA TRANSMITTER

HSS-400 is the most unique camouflaged transmitter the Tx module is embedded in the umbrella handle. HSS-400 can be use as a real functioning umbrella.

Specification:

SIZE... 320 x Ø60mm / Handle Ø36 x 91mm

WEIGHT... 283g (with 2 AA batteries)

POWER SUPPLY... "AA" (R6P / LR6) type battery (1.5V) x 2, / 6LR61) x 1

BATTERY LIFE... 890h (LR6 x 2), 130h (6LR61 x 1)

AVAILABLE CHANNELS... UHF-A, UHF-B, UHF-C

MIC EFFECTIVE RANGE... 15m from circle Point



HSS-40 UHF ANALOG LONG RANGE TRANSMITTER

High quality long range Audio Tx. easy one switch operation, High ratability, high sound quality, long range Tx & long term Tx makes the HSS-40 a great tool for gathering inelegance.

Specification:

SIZE... 30 x 18 x 70 (74)mm / Antenna Ø3 x 220mm

WEIGHT... 118g (with alkaline batteries) / Antenna 3g

POWER SUPPLY... "AA" (R6P / LR6) type battery (1.5V) x 2

BATTERY LIFE... Approx. 420h (alkaline) / Approx. 260h (manganese black type)

AVAILABLE CHANNELS... UHF-A, UHF-B, UHF-C /

SPECIAL CHANNELS: UHF-D, UHF-E, UHF-F

MIC EFFECTIVE RANGE... 15m from circle point





Security and Intelligence Advising

Tx RANGE Approx 200m (in side a city)

HSS-400 UHF ANALOG - MICRO SIZE TRANSMITTER

High quality micro size Audio Tx, No operation switch, just slide the battery into the unique HSS-400 slot & it's start working.

High ratability, high sound quality, long range Tx makes the HSS-400 a great tool for gathering inelegance.

Specification:

SIZE... 33(35) x 27 x 17.5mm / Antenna Ø3 x 185mm

WEIGHT... 10g (with a lithium battery) / Antenna 1g

POWER SUPPLY... Lithium button battery CR-2032(3V) x 1

BATTERY LIFE... Approx. 40h

AVAILABLE CHANNELS... UHF-A, UHF-B

MIC EFFECTIVE RANGE... 15m from circle point

Tx RANGE Approx 150m (in side a city)



HSS 800 UHF ANALOG TRANSMITTER FOR DIGITAL TELEPHONE

HSS 800 enables you to monitor targeted line including digital phone. HSS 800 is set between a telephone main body and its handset The current on this part is lower than that of telephone line. So batteries are required to activate transmitter.

Specification:

SIZE... Ø15 x 500mm

WEIGHT... 49g(without batteries)

POWER SUPPLY... silver oxide button battery SR-48W(1.55V) x 2

BATTERY LIFE... approx. 6 hours





Security and Intelligence Advising

HSS MS1UHF ANALOG - MOUSE TYPE TRANSMITTER

Since the first mouse appeared in the late-sixties, various types of mouse were developed. Now the HSS MS1, new type of mouse appeared on the scene. Embedded with highly sensitive microphone inside. Of course it works as an USB optical mouse too, No power supply needed HSS MS1 takes its power from the USB.

Specification:

SIZE... 66 x 98 x 36mm / USB cord 120cm
WEIGHT... 80g
POWER SUPPLY... No battery needed, power supplied from USB
CHANNELS... UHF-A, UHF-B, UHF-C
MIC EFFECTIVE RANGE... 15m from circle point
OS... Windows 98, Windows 98SE, Windows ME, Windows 2000, Windows XP



HSS-VOXER UHF ANALOG VOX CARD TYPE TRANSMITTER

The thinnest transmitter, HSS-VOXER is card type transmitter. Sole model equipped with VOX function, which means once it stops recognize noise The HSS VOXER stop the Tx up until it recognize noise again in its effective mic range. You can carry it in your chest pocket and also it is easily concealed in a pass holder.

Specification:

SIZE... 54 x 85 x 6mm
WEIGHT... 27g (with a battery)
POWER SUPPLY... Lithium battery CR2430 (3V) x 1
BATTERY LIFE... Approx. 50 hours
AVAILABLE CHANNELS... UHF-A, UHF-B, UHF-C
MIC EFFECTIVE RANGE... 10m from circle point.





Security and Intelligence Advising

HSS 110/220 UHF ANALOG - 110V/220V TYPE TRANSMITTER

The HSS 110/220 room transmitter provides continuous room monitoring once it connects to the 220V or 110V AC power wire, the HSS 110/220 supplied with two clip cord for fast installation.

Specification:

SIZE... 13.5 x 17 x 43mm / Clip cord
12cm
WEIGHT... 15g
POWER SUPPLY... AC220-240V (U-
220CHIBI), AC100-110V (U-110CHIBI),
AVAILABLE CHANNELS... UHF-A, UHF-
B, UHF-C
INSTALLATION... Parallel connection at
mains lines.
MIC EFFECTIVE RANGE... 15m from
circle point

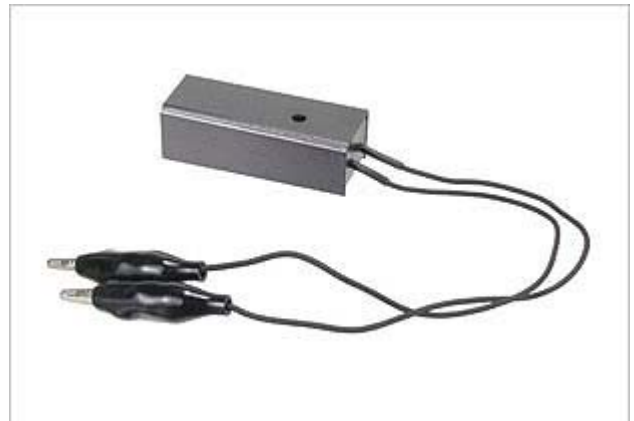

HSS-500 UHF ANALOG - MICRO SIZE TRANSMITTER

High quality micro size Audio Tx, No operation switch, just slide the battery into the unique HSS-500 slot & it's start working.
High reliability, high sound quality, long range Tx makes the HSS-500 a great tool for gathering intelligence.

Specification:

SIZE... Ø28 x 13mm / Antenna 90mm
WEIGHT... 11g (including battery)
POWER SUPPLY... Lithium button battery
CR-2032(3V) x 1
BATTERY LIFE... Approx. 30h
AVAILABLE CHANNELS... UHF-A, UHF-B
MIC EFFECTIVE RANGE... 15m from circle
point
Tx RANGE Approx 150m (in side a city)





Security and Intelligence Advising

HSS 900 UHF ANALOG - TRANSMITTER FOR DIGITAL TELEPHONE

HSS 900 is long term curl cord transmitter. Transmitter box is separated to maintain the flexibility of curl cord and prolong battery life. HSS 900 is set between telephone main body and receiver. The current on this part is lower than that of telephone line. So batteries are required to activate transmitter.

Specification:

SIZE... Transmitter Box 45 x 65 x 25mm / Curl Cord 33cm / Box-Curl Cord Cable 70cm
WEIGHT... 87g(with batteries)
POWER SUPPLY... AA type x 2
BATTERY LIFE... approx. 77 hours(alkaline) / 38 hours(manganese)



HSS-SLEEPER UHF ANALOG - CONTROLABLE TRANSMITTER

High quality controllable Audio Tx. The HSS-SLEEPER have a long battery life time- UP TO 1000h- stand by mode & control of the ON/OFF switch from a distance of approx 100m, The transmitter & the receiver have a unique code between them to avoid interference if more than one unit is working in the same surrounding. Spectrum analyzers cannot detect the unit once it on the sleep mode. High ratability, high sound quality, long range Tx makes the HSS-SLEEPER a great tool for gathering inelegance.

Specification:

SIZE... 67 x 21 x 70 (73)mm / Antenna Ø3 x 220mm
WEIGHT... 162g (with alkaline batteries) / Antenna 3g
POWER SUPPLY... "006P" (6F22/6LR61) 9V battery x 1
BATTERY LIFE... Approx. 62h (6LR61, continuous transmission) / Approx. 1000h (stand-by mode, no transmission)
AVAILABLE CHANNELS... UHF-A, UHF-B
MIC EFFECTIVE RANGE... 15m from circle point
SIZE... 42.5 x 21 x 112 (120) mm / Rod antenna 20mm (shortened) - 460mm (extended)
WEIGHT... 162g (with alkaline batteries) / Antenna 3g
POWER SUPPLY... "006P" (6F22/6LR61) 9V battery x 1
BATTERY LIFE... Approx. 11h (6LR61, continuous)





Security and Intelligence Advising

HSS-10R UHF 3CH RECIEVER

The HSS-10R has DC9V input and Ø3.5mm earphone jack that matches to any earphone. On board DC9V input is very useful for a long hour receiving. Regular type is supplied with UHF-A, B and C channels. HSS-10R offer toughness, usability and high sound quality.



Specifications:

SIZE... 56 x 21 x 83 (99)mm / Antenna Ø10 x 190mm
WEIGHT... Main body 195g (including manganese battery) / Antenna 8g
POWER SUPPLY... 9V (6F22/6LR61) battery x 1 or AC adapter (DC9V)
BATTERY LIFE... Approx. 30 hours (alkaline)
RECEIVABLE CHANNELS... 3 channels; UHF-A, UHF-B, UHF-C
INPUT & OUTPUT
Antenna -SMA jack / Earphone output -Ø3.5mm monoral mini jack /
Recording output -Ø2.5mm monoral mini mini jack / DC input -Ø2.5mm normal mini jack



HSS-100M UHF 2CH RECIEVER

HSS-100M is the most smallest receiver. It matches to our UHF transmitter. HSS-100M receives UHF-A and B channels.

Specifications:

SIZE... 45 x 19 x 63 (75)mm / Antenna Ø10 x 190mm, Ø10 x 73mm
WEIGHT... Main body 165g (including battery) / Antenna 8g, 11g
POWER SUPPLY... Lithium camera battery 2CR1/3 (6V) x 1
BATTERY LIFE... Approx. 13hours
RECEIVABLE CHANNELS... 2 channels; UHF-A, UHF-B
INPUT & OUTPUT... Antenna SMA jack, earphone output-Ø2.5mm



HSS 100R UHF CARD RECIEVER

HSS 100R is the thinnest UHF receiver – only 6mm. Easy operation, just plug in the headphone antenna & it's starts working.
Easy to hide & carry.

Specifications:

SIZE... 55 x 85 x 6mm , WEIGHT... 28g (with a lithium battery) /
Earphone 7g
POWER SUPPLY... Lithium button battery CR-430(3V) x 1





Security and Intelligence Advising

BATTERY LIFE... Approx. 7h

AVAILABLE CHANNELS... UHF-A, UHF-B, UHF-C

HSS-555 Multi Purpose Wall Contact Microphone Set

Ordinary wall contact microphone is not enough for your investigation kit, then we recommend you our newest model, HSS-555. HSS-555 is a multi functional wall contact microphone you can use it as a wall contact microphone / HSS-555 Equipped with hollow needle mic 2 different types of needles are supplied for max fitness to working surrounding.

Specifications:

SIZE... Amplifier unit 21(23) x 55 x 70 (85)mm / Contact mic. Ø32 x 27(30)mm Cord 97cm / Needle mic. Ø8 x 28mm (Mic. head) -Cord 105cm- (Needle Ø6 x 114mm, Ø6 x 57mm) / F-555EX 25m remote mic. Ø7 x 12 (Mic. head) -Cord 25m

WEIGHT... Amplifier unit 184g (with an alkaline battery) / Contact mic. 98g / Needle mic. 11g & 12g / F-555EX 25m remote mic. 147g

POWER SUPPLY... 9V (6F22 / 6LR61) battery x 1

BATTERY LIFE... Approx. 55-60h (alkaline)

INPUT & OUTPUT... Contact mic. input Ø2.5mm monoral mini mini jack / Remote mic. power supplied input Ø2.5mm monoral mini mini jack / Record output Ø2.5mm monoral mini mini jack / Earphone output Ø3.5mm stereo mini jack.

OPTIONAL ITEMS... Remote microphone, 3m, 10m, 25m, 50m.





Security and Intelligence Advising

HSS-999 Super Sensitive Wall Contact Microphone

The flagship of our contact microphone, The HSS-999 have an advanced and improved stability of the amplifier circuit and also in durability of the board comparing to previews models.

HSS-999 has Highly sensitive heavy brass metal microphone and Sound Filter -4 different band selectable, it has Limiter to protect your ear from sudden big sound.

Specifications:

SIZE... Amplifier unit 64 x 22 x 98mm / Microphone Ø36 x 30mm Cord 1m

WEIGHT... Amplifier unit 284g / Microphone 119g

POWER SUPPLY... 9V (6F22 / 6LR61) battery x 1

BATTERY LIFE... Approx. 50h (alkaline)

SOUND FILTER... 4 different band selectable. "0" = Through, "1" = Boost low band and decrease high noise, "2" = Boost high band decrease low noise, "3" = Boost targetted human voice.

SOUND LIMITER... Automatically cut sudden big noise. Normal sound level recovers after a couple of seconds.

INPUT & OUTPUT... MIC input Ø3.5mm monoral mini jack / Earphone output Ø3.5mm stereo mini jack / Record output Ø3.5mm monoral mini jack.

ACCESSORIES... Contact MIC guard plate, MIC extension cord, Contact MIC adhesive tape, Stereo Earphones.

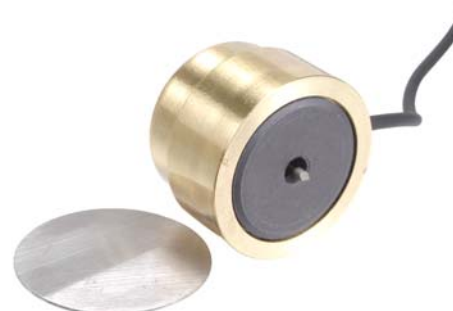

■ ND-M2 – DIGITAL RADIOMICROPHONE WITH REMOTE CONTROL



The **ND-M2** radiomicrophone is designed to transmit acoustic information via radio channel with delta-modulation and digital encoding.

The **ND-M2** is a basic digital module with the built-in remote control.

The transmitter is based on a three-cascade scheme. The frequency synthesizer can be preset to generate operating frequencies with up to 1 kHz accuracy within 410 to 424 MHz frequency range. In conjunction with other modules, such as power units, microphones, stethoscopes, inductive sensors, etc., various audio monitoring complexes can be assembled.

The device is equipped with the multifunctional **TRC-2** remote control transmitter, which enables to change the output power and switch between F1 and F2 frequencies.

The built-in super-heterodyne remote control receiver with high-quality pre-selector increases the RC channel noise-immunity.

The unit is protected from the wrong polarity.

The transmitted signal can be received by the **UNIVERSAL** dedicated receiver only.

Specifications	
Data transmission channel	
Operating frequency range, MHz	410÷424
Modulation	FSK
Deviation, kHz	50
Data transmission rate, kbps	100
Output power and current consumption in various operation modes, mW/mA	
■ "LOW" — low output mode	20/40
■ "MID" — medium output mode	40/60
■ "HIG" — high output mode	90/90
Data transmission channel dynamic range, dB	45
Microphone input dynamic range, dB	89
Low frequency range, Hz	200÷6000
Power supply, V	3.5÷7
Average current consumption in stand-by mode, mA	0.3
Remote control channel	
Operating frequency, MHz	315
Modulation	ASK
Sensitivity, µV	1.5
TRC-2 remote control transmitter	
Operating frequency, MHz	315
Output power, mW	1000
Modulation	ASK
Power supply (AAA type batteries, 4 pcs), V	6
Current consumption:	
■ stand-by mode, µA	40
■ transmitting mode, mA	400
Operating distance, m, not less than	200
Dimensions (without antenna), mm	130×42×20
Weight, gr	150
Operating temperatures range, °C	0÷+40
Humidity, %	85
Dimensions, mm	52×17×6

Complete set

- **ND-M2** radiomicrophone with the remote control receiver
- TRC-2 remote control transmitter
- Transmitter antenna
- External microphone
- BP-135 AC/DC small-sized adapter (220 V/3.3 V — 135 mA) (optional)



Security and Intelligence Advising

UNIVERSAL – DEDICATED RECEIVER WITH RECORDING CAPABILITY

The **UNIVERSAL** small-sized special receiver is designed to receive and record analog and digital signals from radiomicrophones and wiretap transmitters.

The **UNIVERSAL's** operating frequency range — 410÷424 MHz. This frequency band can be scanned automatically and with high speed to detect the radio signals.

It is remarkable for its high sensitivity, selectivity and adjustable level of noise reduction.

The **UNIVERSAL** receiver is able to receive analog signals with ± 15 kHz frequency deviation (NFM mode) and ± 50 kHz frequency deviation (WFM mode). The receiving and decoding of signals with digital encoding is available only in the WFM mode.

Due to the frequency synthesizer and the microprocessor control, the receiver can memorize up to 10 frequency channels within the operating frequency range. Audio data can be recorded to the built-in flash memory. Record playback is available.

High quality of audio recording is confirmed by the phonoscopic tests made by the Institute of Criminalistics.

The built-in nonvolatile memory allows to keep the receiver's settings for a long time in case of batteries or external power supply failure.

Small-sized user-friendly receiver is an ideal tool for security applications.



Comprehensive LCD shows the essential and sufficient information:

- frequency;
- scan mode;
- signal level;
- memory status;
- noise reduction status;
- batteries level;
- signal type indication — analog/digital;
- date and time;
- NFM/WFM operation mode.

The receiver's keypad allows to:

- switch the receiver on/off;
- tune with 5, 10, 25 kHz steps;
- adjust volume;
- switch between the memory banks;
- switch the record mode on/off;
- set noise reduction level;
- set LCD backlight duration;
- set date and time;
- set NFM/WFM operation modes.

Jacks for peripheral equipment:

- external recorder;
- headphones;
- DC-IN.



Security and Intelligence Advising

VIP PROTECTION SYSTEM

Complete mobile high-end rigid security system for VIP protection, swat teams, intelligent units, army and police units etc'.

The system is designed for fast deployment in places where fixed security system is not an option.

The system combines CCTV monitoring, wireless alarm system and panic button into one system that allows the user total control in real-time.



The system supplied with logistic case for convenient transport and it is built for the move.

Wireless Alarm System:

- 3 units of wireless PIR detectors – for indoors use.
- 1 unit of wireless magnetic sensor – for doors / window

Once the detector is triggered the main unit will alerts by both Beep and Light indications that will show which area has been activated. SMS notification is optional.

Wireless PANIC Button System:

The system supplied with a panic button that transmit a stress signal to the main unit.

SMS notification is optional.

Wireless and Weird CCTV System

- 3 pcs. of wired hidden CCTV camera 1/3" CCD 2.8mm lens. Supplied with 20m cables.
- 1 unit of wireless hidden CCTV Camera with internal battery for 10h, 1/3" CCD 2.8mm lens hidden camera.
- 10.4" LCD TFT adjustable screen.
- 4 Channels 100fps DVR,(digital video recorder) 250G HD.
- T.V out – to connect the unit to a bigger screen.

This product is manufactured according to the customer's specifications and needs. We can add, change or improve any component according to your needs

Effective range for all wireless components is up to 100m open areas



Security and Intelligence Advising

Electronic Ambush Rigid System



System info:

Professional video recording system based on 4 channels DVR with 250GB HD. The system is completely sealed, rigid and designed to be berried under ground.

To the system connected up to 4 stone covert professional B/W camera for night view at minimum illumination of **0.0003 LUX!** – Optional IR illuminators for 0 LUX conditions.

The system records continually or once it detect motion,(VMD), generation 2 of the product offers SMS alerts and remote unit control.

The system supplied with internal 10h battery or more then 1 week with external power case.

The system offers WiFi abilities to view the cameras in real-time mode or downloading selected record to a laptop computer.

Optional outdoor PIR detectors / tramping stripe to alert via SMS / trigger the system.

Each system is custom made to the specific surrounding of the working areas and can be changed to the unique demands of each customer



Security and Intelligence Advising

Powerful Hand Held Hidden Surveillance System

Professional powerful hidden surveillance camera hidden in a hand held bag for long-range documentation under hushes surrounding.

The system includes a high quality CCD camera with adjustable electronic optical zoom up to X 36 for full-face recognition even at low light conditions and long distance. A hidden mini box connected directly to the camera provides covert, easy and simple operation. Mini size DVR and high power batteries are installed also in the bag allowing a full solution.



Aiming to the target from long distance its not easy but with this system does not require any specialty. Inside the bag there is a hidden low power Video Transmitter that transmits the video to a hand held wireless Video receiver with a 1.8" LCD screen that looks like a cell-phone. The operator can "look at his phone" and aim the camera to the right position.

The RF transmitter inside the bag can be switched on / off at any time by a hidden switch.

- Best quality MPEG-2 video recorder is used to provide approx. 2Hrs of continues recording time.
- High quality MPEG-4 Video recorder is used to provide more then 4Hrs. of continues recording time.

The system is custom made and can be modified according to the user special needs.

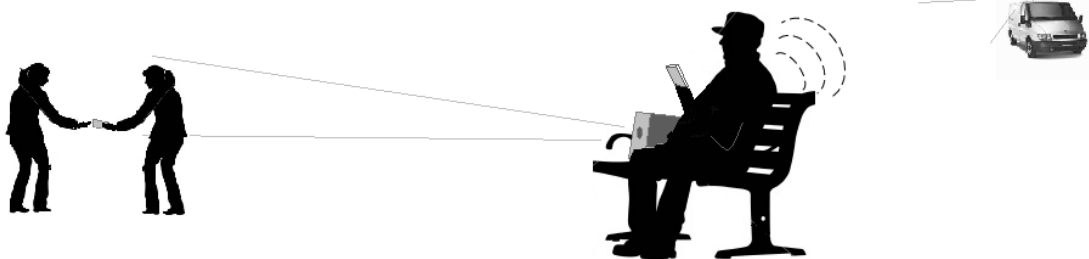

Optional upgrades:

- Digital / Analog video transmitter for real time surveillance
- Remote viewing over TCP/IP



Security and Intelligence Advising

SPY PHONE – GEN 5

Haboleshet SpyShop Ltd .distributes the most advanced remote monitoring software for mobile phones available. Completely stable and flawless in operation the Full Suite is a fully feature packed “security file” that intelligently operates in its own environment with absolutely no indication of installation logs, pre-defined number logging or any indication of connected calling. There is absolutely no tampering of the handset and no conflict with the normal operation of the handset whatsoever.

The Remote Control Management Tool is possibly the smartest addition to the software development. The remote control feature allows the PDN to send invisible commands, which are not recognized by the TP to control the activation, de-activation of the features and also change the pre-defined number at any time.

FEATURES

- **Spy phone** (listen in)
- **Text Forward**
- **Text Alert**
- **Call Interception**
- **Boot/SIM change**
- **Location** (SIM network dependant)
- **Reboot**
- **Uninstall**
- **Phone Dead**



Whenever the Target Phone makes or receives a call, a notification SMS is immediately sent to the PDN indicating the direction of call (incoming/ outgoing) showing the actual number of RP. At this moment the PDN has the option to make a call to the TP and intercept the conversation. The TP will create a conference and allow the PDN to listen clearly to both sides of the call.

COMPATIBLE MODELS

3230, 6600, 6260, 6620, 6630, 6670, 6680, 6681, 6682, 7610, N70, N72, N73, N80, N90, N91, N95, E50, E60, E61, E62, E70, 3250



Security and Intelligence Advising

Security Encrypted Mobile Phones

The fastest and easiest way to provide your customers with the power to engage in two-way, fully-encrypted, private cellular voice communication as well as sending and receiving encrypted text messages during any secure call.

This technology is available with even better audio quality than before supported by all of these popular Nokia phones:

- Nokia 6630
- Nokia 6680
- Nokia N70
- Nokia N90

We ship these security phones to you in 2 ways:

1. The Complete Package – The Nokia phone is installed and shipped directly to your complete with the inscription software from Israel. All you do is deliver the phone to your customer. We remain transparent throughout the transaction and will never contact your customer directly.
2. The Software Package – The Nokia phone is locally purchased by you. We deliver the software directly to you by email along with our easy-to-use installer and simple instructions. You simply install the package into your customer's supported phone via choice of Bluetooth, infra-red, or data cable. No shipping costs, No import taxes, immediate delivery.

How does it work?

Whenever a customer needs to make a secure call, or secure texts communication, he/she simply presses and holds the C button in the keyboard to initiate a fully encrypted session.

The call switches back to standard clear mode when the call is finished. Whenever the secure call is initiated, our software kicks in the encrypt the voice of text data using a constantly changing mathematical formula which creates a 1024 bit asymmetric key based on the RSA algorithm, as well as changing session key which replaces the encryption every second. Not only is the encryption software the perfect choice for politicians, lawyers, police and governmental agencies, executives, and anyone else who recognizes the need to prevent confidential information from falling into the wrong hands, but the encryption algorithms we use are so secure that our software has been licensed by the Israeli Ministry of Defense.





Security and Intelligence Advising

HSS UTMP 2 – UNTRACEABLE GSM PHONE

To keep a conversation secure from interception possibilities of equipment connected directly to the switch, (so called lawful interception), it is not enough to purchase pre-paid SIM card and replace it every once in a while.

The interception equipment not only tracking the identity of the SIM card - IMSI, (International Mobile Subscriber Identity) , it also monitors the identity of the handset it self – IMEI, (International mobile equipment identity).

To make sure that the user is totally untraceable both IMEI and IMSI needs to be change together.

The HSS UTMP 2 mobile phone is modified in a way that every time the SIM card is replaced the IMEI will change automatically. The IMEI numbers produced by the cellular phone is random and will never repeat so the mission of intercepting the conversation becomes impossible.



The IMEI is a unique 15-digit code used to identify an individual GSM mobile telephone to a mobile network. This number can be displayed on most phones by dialing the code `*#06#`.

The numerical format of the IMEI code is: 111111-22-333333-4

TAC					FAC		SNR						CD	
D14	D13	D12	D11	D10	D09	D08	D07	D06	D05	D04	D03	D02	D01	

TAC – type approval code – this code identifies the country which type approval was sought for the phone as well as the approval no.

FAC – final assembly code – identify the company manufactured the mobile phone.

SNR – serial number – is a six digit code, which has been uniquely assigned to the specific type of hand set. The CD –check digit is use to check the IMEI for its validity for phase 2 and phase 2+ handsets. Phase 1 GSM handset always have '0' as check digit.



Security and Intelligence Advising

RMP – RECORDING MOBILE PHONE

HSS RMP-2 is the perfect tool to record & document dissuasions, meetings, conversations and incoming / outgoing calls with out suspicion. The phone doesn't have any indication on the screen when it's records and continue on recording the room even when an ongoing call is accrued. HSS RMP-2 offers simple one button operation. All of these unique futures insure that the user won't be exposed even on a very suspicion surrounding.

Specifications:

OPARATION: single press of a button.

REC TIME: up to 9h based on the internal memory only

FILE DOWNLOAD: Blue-Tooth / USB

MEMORY CARD: Micro SD (optional)



The picture is for illustration only



Security and Intelligence Advising

HSS-1210 ,HSS-1220 PRO MINIATURE WIRELESS EARPHONE



The HSS-1210 miniature earphone is a small wireless micro receiver that used with a hidden inductive loop that can be connected directly to a cellular phone or via a BT, (Bluetooth) adaptor. Combined with a sensitive microphone the system provides full two-way covert communication. When using a BT adaptor the phone can be up to 10m away from the user.

The unit is perfect for situation the user doesn't want anybody to know that he is connected online and getting info at real time.



The HSS-1220 is a small miniature earphone that works with out the inductive loop. It provide only listening abilities once paring to a remote radio transmitter.

No wiring needed on the user, just the miniature earphone!!

The units are in use at Police surveillance, Privet investigators work, VIP security, lectures, meetings, secret prompter and even politicians...

SHORT RANGE IR ILLUMINATORS - IR 112/120

High power infrared illuminator with a wide angle performs smooth illumination like an ordinary ceiling lamp. It is designed especially for home/office rooms illumination to provide "one unit is enough" cheap decision. Its simple design provides its reliability.



Tasks solved by ceiling illuminator: Illumination of the room with the only one illuminator. Wide angle and vertical beam axis orientation allows to use CCTV cameras at any location to observe the room.

Specification:

- Illuminated indoor area: 8x8 m (for 0.1 lux sensitivity cameras)
- Wavelength: 880 nm (dull red glow) or 940nm (invisible to the human eye)
- Total optical radiation output: 0.8 W
- Power supply: 12±0.6V, current consumption 1.6A
- Operating temperature: -30.. +40°C
- Dimensions: 180x96x29 mm (case only)
- Weight: 0.8 kg
- Protection Standard: IP65

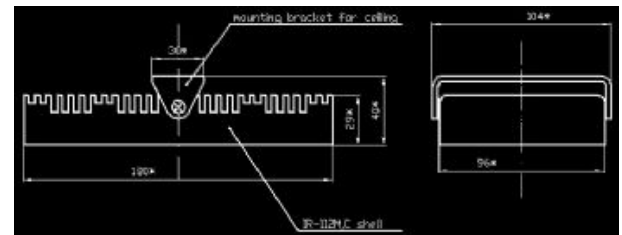

SHORT RANGE IR ILLUMINATORS - IR PLATE

The plate is designed for a covert illumination of observation objects when there is no light or the intensity of light is insufficient for CCD cameras with the operating range below 0.9 micrometers.

The case of the illuminator is made of aluminum alloys. The front side of the illuminator is protected by special plastic filter. Operation of the device makes neither electromagnetic noise nor sound noise.



Specifications

- Wavelength: 880nm / 940nm
- Illumination range: 3.5m
- Viewing angle: 160°
- Operating temperature: -30°C ... +40°C
- Total radiation output: 0.22W
- Power supply: 12VDC 0.4A
- Dimensions: 106X72X6mm





Security and Intelligence Advising

- Weight: 0.1 kg

SHORT RANGE IR ILLUMINATOR - IR-6

Infrared illuminator IR-6 is intended for covert and semi-covert illumination when there is not enough light for CCD cameras.

The case is made of aluminium alloys by lathing. Could be mounted with standard 1/4" bracket.

The plate is designed for a covert illumination of observation objects when there is no light or the intensity of light is insufficient for CCD cameras with the operating range below 0.9 micrometers. The case of the illuminator is made of aluminum alloys. The front side of the illuminator is protected by special plastic filter. Operation of the device makes neither electromagnetic noise nor sound noise.



Specifications

- Wavelength : 880nm (dull red glow) / 940nm
- Total optical output of radiation: 0.15 W
- Operating temperature: -30... +40°C
- Power supply: 12±0.6V, 0.2A
- Dimensions: Ø34x27.5 mm (case only)
- Weight: 0.04 kg
- Protection Standard: IP55

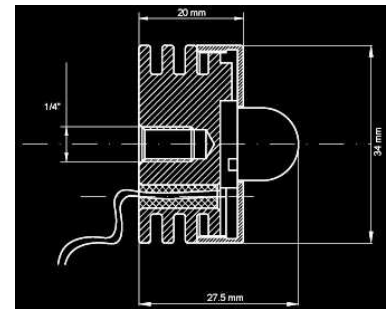

MIDDLE RANGE ILLUMINATORS - IR 21

Infrared illuminator IR-21 is intended for covert illumination at absence or in conditions of insufficient illumination for CCD cameras sensitive to IR radiation in a range up to 0.9 microns. The illuminator works on powerful light-emitting diodes and intended for most required cases. The case of the illuminator is made of aluminum alloys. The filter made of special plastic covers illuminator face.



Specification:

- Wavelength: 880 nm (dull red glow) or 940 nm
- Total optical output of radiation: 0.11 W
- Operating temperature: -30... +40°C
- Power supply: 12±0.6V, current consumption 0.2A
- Dimensions: 74x35x30 mm

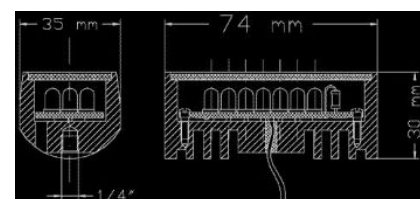

IR OFF

IR ON

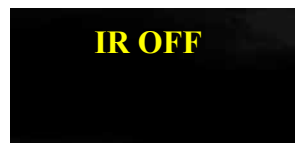



Security and Intelligence Advising

- Weight: 0.12 kg
- Protection Standard: IP66 ,
- Approx 20m illumination range

STING I – MINIATURE PRO DVR

STING™ the original miniature feature packed Digital Video Recorder. Measuring just 78mm x 60mm x 23mm, including internal Lithium Ion battery, this unit can be used in multiple applications & countless scenarios requiring miniature high-quality video & audio recording. Sting allows smooth operation, anytime, anywhere by interfacing with a variety of accessories; Computers and laptops - for on-the-go convenient viewing via; PCMCIA adapter - for fast backup and retrieval of captured materials USB for playback or downloading of files.



Features:

- Trigger input for motion detection devices
- 3.5mm jack socket for A/V input
- NTSC & PAL compatible
- LED verification
- Detachable vibrating remote control with FailSafe video sync detect circuit
- Internal Lithium Ion battery powers the STING™ for 2 hours
- Removable Compact Flash that can be switched out on the field in seconds
- 5V dc output to power a camera directly from the STING™ battery



STING MINI – PRO DVR

Sting Mini™, the smallest digital audio/video recorder in the Sting™ Range at only 60 x 40 x 18 mm.

The Sting Mini™ includes an internal Lithium Ion battery and Time/Date stamp, features MPEG-2 compression and boasts full screen DVD image quality. It records on a 2 Gb SD card for up to 1 hour.





Security and Intelligence Advising

STING II – MINIATURE PRO DVR



the field of miniature covert surveillance equipment.

Providing extensive wired and wireless communications options including, internet, GPRS, direct connection to monitor/television for playback.

The Sting II™ also features built-in motion detection, file encryption, time-lapse recording mode, time / date stamp and watermarking.

Packaged in a 92 x 62 x 27mm housing, including lithium ion battery the applications that Sting II™ can be used in are endless. USB for playback or downloading of files.

- Composite video input
- Composite video output, which can be switched between live monitor view and recorded playback
- Media files can also be viewed on a PC - using Windows Media Player
- MPEG-2 video compression
- Water mark
- File encryption
- Recording in time lapse mode
- Internal Lithium-Ion rechargeable battery
- Configurable time/date stamp
- Hi-speed USB OTG connector
- Supports connection via WI-FI and Ethernet networks (via docking bay)
- Vibrating remote control with Fail Safe video sync detect



Security and Intelligence Advising

STING / MOBILE DVR CAMERA ACCESSORIES

Pen camera

- 1/4 Inteline CCD image sensor
- 3.7mm 72 Deg.FOV built-in lens
- Internal synchronizer
- 1.5 Lux color luminance
- 380 lines horizontal resolution
- 0-18dB AGC Auto
- 48dB S/N ration
- 1 Volt p-p video output
- 1/60-1/30000 Sec. Electronic iris



Button camera

- 380 lines H.Res
- >46dB S/N Ratio
- 3.7mm Lens
- 72 Deg. FOV
- 1.5 Lux
- 12mm diameter button
- Dimensions: 26mm (W) x 22mm (H) x 14mm (D)
- Weight: 5 grams



Glasses / earphone camera

- 380 lines H.Res
- >46dB S/N Ratio
- 3.7mm Lens
- 72 Deg. FOV
- 1.5 Lux



Necklace camera

- 380 lines H.Res
- >46dB S/N Ratio
- 3.7mm Lens
- 72 Deg. FOV
- 1.5 Lux



Aqua / can cameras

- 380 lines H.Res
- >46dB S/N Ratio
- 3.7mm Lens
- 72 Deg.FOV , 1.5 Lux





Security and Intelligence Advising

Sting Xtreme™ Helmet Video Gear



The Sting Xtreme™ (helmet video gear) is HSS new revolutionary digital audio/video helmet recording system. What makes it revolutionary is that it a self contained modular system. No more interfering wires running from the helmet to the body! The high resolution camera and Sting® II digital recorder are both attached to the helmet. Furthermore, **The PATENT PENDING** clip-on attachment allows you to easily remove and reattach the system to almost any helmet in the market including Military, Police, Fire, Rescue, Ski and Motorcycle helmets among others.

The rugged, water resistant, shock absorbent and aerodynamic casing of the Sting Xtreme™ helmet video gear makes it exceptionally resilient in rough environmental conditions and makes it highly suitable for use in extreme work environments such as police, riot control, paratroopers, rescue units, extreme sports, etc.

The plug-and-play system can be connected to any display unit (monitor, TV, computer, etc.) for playback. Its 480 line resolution color camera provides high quality video in daylight and low light conditions. An optional video transmitter is available with this unit if live viewing at the control center is required

Features/Specifications

- Composite video output, which can be switched between live monitor view and recorded playback
- Media files can also be viewed on a PC-using any standard Window Media Players*
- MPEG-2 video compression in full D1 format and compression, supporting up to 8 mbit/sec video bit rate
- Water mark: Media files have a signature to verify that the video has not been tampered with
- Encryption: Media files can be optionally encrypted with a user-generated software key
- These files are viewable onboard with a password, or with a PC player after decryption
- Internal Lithium Ion rechargeable battery, which allows the Sting® II to operates for approximately three hours
- Video is embedded with a visible time/date, stamp in a configurable location Hi-speed USB 2.0 connector.
- Ethernet 10/100 port that supports the IP, TCP, UDP, DHCP protocols. Supports file transfer through a web interface from a remote PC
- Built-in vibrating motor with Failsafe video sync detect circuit, including end of memory & low battery warning





Security and Intelligence Advising

HSS PR-200 Advanced Portable Through Wall Radar

HSS PR-200 offers world leading Performance in Through-wall monitoring with the convenience of a self-contained, Lightweight, portable unit.

The unit employs UWB Radar to give high-resolution Real-time radar images of Complex scenarios in an Adjacent room where non-invasive Surveillance is essential.



HSS PR-200 can quickly evaluate if there are people moving around in a room or can be used over Minutes or hours for collecting more detailed intelligence, leading to selecting the best time and place for a forced entry. The sys gives a tactical advantage to Police and Special forces through increased situational awareness where discreet surveillance is an essential part of operational planning and execution. The unit is also an invaluable tool in search and rescue operations for emergency services.

HSS PR-200 can resolve a number of moving objects to enable the operator to quickly assess a situation covertly and to aid categorization of threats, victims and obstacles. From a single, fixed location, the radar unit generates a moving 3D representation that is updated in real time. The latest signal processing gives an unsurpassed level of clarity. Information is presented to the user with a very high degree of confidence to aid rapid decision-making in critical operational situations. Multiple moving objects are resolved and can be viewed from a variety of virtual viewpoints. The system is light and portable, allowing rapid deployment.

HSS PR-200 user interface presents target location in 3 dimensions, through plan, side elevation and front elevation perspectives of the same room. A three dimensional view is also available

Operator actions remain simple, with textual and icon style information that includes target co-ordinates and other operational graphics.

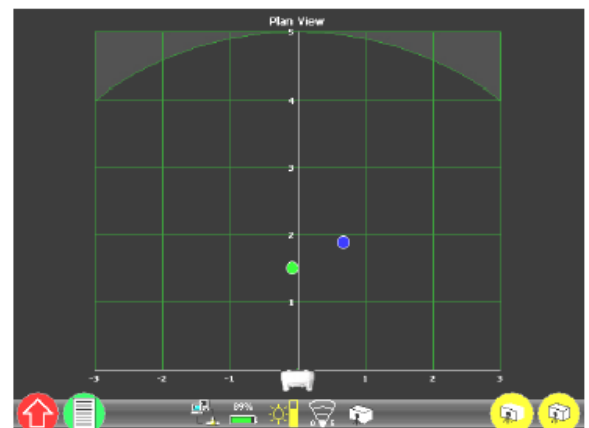
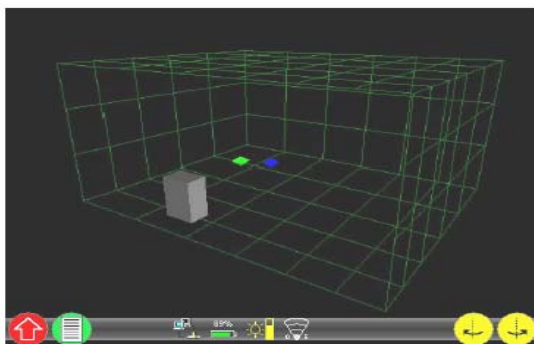



Security and Intelligence Advising

HSS-4280 – OPTICAL MICROPHONE



Professional sensitive fiber optic microphone, that captures from a soft whisper to a normal room conversation.

Due to a unique sensor technology the microphone provides excellent sound accuracy and performance.

A beam of light is sent through the fiber to a sound sensitive membrane, sound waves causes this membrane to vibrate and modulate the intensity of the light reflected from it, than the light is translated to an electrical signal.

The microphone provides a high SNR, (sound to noise ratio), so even low level sound inputs can be heard clearly from many meters away.

The HSS-4280 cannot be detected by electromagnetic means since the microphone head neither contains metal parts nor generates electromagnetic fields; the main unit is separate meters away from the monitored room by fiber optic cable.

The HSS-4280 can be installed in many ways to elude discovery by naked eye or highly sophisticated Non Linear Junction Detectors.

The HSS-4280 can be customized to your needs with the following variables:
Fiber length, type, color and different head types.



Security and Intelligence Advising

OPTIC INSPECTION SYSTEMS

Haboleshet Spy Shop Ltd offers an extensive range of professional inspection and covert operations viewing systems. All instruments are sealed against ingress of water, oil and aviation fuel, and provides good resolution and system durability.

Rigid Endoscopes - with lengths up to 0.2m and diameters of 1.5mm-15mm, several viewing angle, 35° to 55° FOV, adjustable focus with a distance of 4mm to infinity and illumination connector.



Flexible Endoscopes- (Borescopes) – with lengths up to 3000mm and diameters of 3.2,4,6,8mm, Tip articulation: 2 and 4 way direction with locking, FOV 60°, adjustable dioptre eyepiece, depth of field 4mm to infinity and illumination connector.



Under door board – flat pack near IR lightning for room illumination, light output wavelength 940nm combined with a high sensitivity B/W camera connected to a 3.5mm semi-flexi scope. The image is displayed on a LCD screen. Optional voice recording capabilities.



Pole camera system – the pole camera system uses the latest CCD chip technology to optimize performance for fast search applications, the system are available both in monochrome or color and with covert IR or white light LED's. the products are perfect for inspecting cars, trucks, ceilings, pipes and even under water cameras up to 50m depth.



Video microscopes – hand held surface contact and / or stand mounted, color remote head CCD chip video format microscope. Magnification from 25X to 1000X, non contact probes, offer magnifying lens options from 5X to 200X





Security and Intelligence Advising

SE 35 handheld Thermal Camera

Description

The TACSIGHT™ SE 35 **handheld camera** provides night vision capability for civilian and paramilitary surveillance, detection and protection applications. TACSIGHT™ SE 35's powerful surveillance capabilities enable the user to effectively detect a person from a distance of over **650** meters and a vehicle from about **1300** meters.

Applications

TACSIGHT™ SE 35 is a powerful **thermal camera** for tactical, surveillance and scene assessment applications.

This thermal imaging tool enables **rescue forces** and **law enforcement** to conduct nighttime perimeter surveillance of sensitive sites and areas, including national borders, pipelines, oil terminals, power stations, communication transmitters, and prisons.

TACSIGHT™ SE 35 enables law enforcement personnel to observe heat signatures of objects, people, and other sources. By detecting extremely small differences in temperature, TACSIGHT™ SE 35 makes it possible for the user to distinguish people from their immediate surroundings. TACSIGHT™ SE 35 is distinct from conventional night vision equipment, which both requires light/special illuminators and suffers from incapacitating particles, including smoke. With TACSIGHT™ SE 35, however, no light or illuminators are needed to generate high-quality images on the darkest nights, and even through smoke. Overcoming the typical limits of night vision, TACSIGHT™ SE 35 prevents suspects from hiding through the veil of darkness and camouflage-since their own body heat gives them away.

Key Features

- Powerful proprietary algorithms, fully tested and
- proven effective under conditions of poor visibility
- Anti-blooming mechanism
- Electronic Zoom x2, x4
- Backlight 3.5" LCD display for arm's length viewing
- Water-tight, extremely durable

Advantages

- Cost-effective
- Lightweight, palm-size design
- State-of-the-art amorphous silicon
- Microbolometer technology
- Unique functional design
- User-friendly interface software
- Simple on-screen menu operations
- Flexible video processing capabilities.





Security and Intelligence Advising

HURRICANE Thermal Camera

Description

The HURRICANE™ is an integrated electro-optical video system that combines a microbolometric IR camera for night vision plus a CCD camera for daytime vision into a single, highly affordable bore-sighted unit. The system is ideal for monitoring sensitive locations or observing potential trouble spots. A key feature of Hurricane™ is that it can be fixed to a solid base at a particular observation point and connected to the display and centralized control, situated at a safe distance. HURRICANE™ can also be vehicle-mounted for mobile reconnaissance and as a weapon sight.



Applications

HURRICANE™ provides round-the clock observation, monitoring, detection, protection and security for military, para-military and civilian applications. The system is ideal for perimeter surveillance of national borders, airport boundaries, pipelines, oil terminals, power stations, communication transmitters, prisons, and other sensitive sites. HURRICANE™ can be used as a weapon sight for heavy machine guns.

Key Features

The OPGAL HURRICANE™ design combines unprecedented ease of use along with a rich set of functionality and features:

Micro-bolometric IR thermal imager for nighttime vision and a CCD camera for daytime vision
Fix mountable to a solid base at particular observation points
Centralized, operator-control from a safe distance (optional)
Vehicle-mounted for mobile reconnaissance and as weapon sight
Modular options optimize a wide range of applications





Security and Intelligence Advising

EYE-SEC Thermal Camera

Description

The EYE-SEC™ is a highly affordable microbolometric video thermal (IR) camera for day/night observation and monitoring of sensitive locations. A key feature of EYE-SEC™ is its rugged design—the system is capable of withstanding the harshest weather and environmental conditions, including rain, direct sunlight, high humidity and dust. What's more, secure within a metal housing unit and protective connectors, the camera is shock-resistant and impervious to acts of vandalism.



Applications

EYE-SEC™ is especially designed for civilian, military and paramilitary surveillance, detection and protection applications. The system enables nighttime perimeter surveillance of sensitive sites and areas, including national borders, airport boundaries, railroads, pipelines, oil terminals, electrical powerhouses, communication transmitters and prisons.

Features Description / Performance

- Focal Plane Array Microbolometer
 - Spectral Range 8-12 μm
 - Number of Pixels (CCIR) 320x240 320x240(388x284) 160x120
 - Pitch 35 μm 25 μm 35 μm
 - Detection Range Human Target
 - 25 mm 260m 370m 260m
 - 35 mm 461m 645m 461m
 - 50 mm 660m 920m 660m
 - 75 mm 990m 1380m
 - 150 mm 2000m 2765m
 - 60/180 mm 1106m/3319m
 - Operating Voltage 9V-12V 7V-9V 9V-12V
 - NETD <70°mk <50°mk <100°mk
 - Temperature Range -20°C - 50°C -30°C -60°C -20°C -50°C
 - Video Output CCIR or RS-170
 - Remote Control RS 422 or RS 232
 - Control Operation Focus (either manual or remote operated - depends on optics)
 - Video Polarity, NUC, Manual Gain/Level
 - Dimensions (with cover) (except 150 mm) 220 x 143 x 143 mm
 - Weight 2 Kg (Depends on optics)
- Environmental Qualification IP 65; MIL-STD 810E; IP 67 optional





Security and Intelligence Advising

EYE-M35 Thermal Camera

Description

The EYE-M35™ is a small sized high performing thermal imaging engine based on a 320x240 pixels (35µm pitch) microbolometer detector. The EYE-M35™ supports both analog (CCIR or RS170) and optionally digital (LVDS or RS422) outputs. the long wave infrared band and has a sensitivity of under 0.07°C with an f/1.0 lens.



Applications

The EYE-M35™ is suitable for a wide range of applications either as a stand-alone camera or as an OEM engine. Such applications include industrial processes monitoring, quality control, security, surveillance and defense.

Key Features

- Powerful and proprietary algorithms that have been fully tested
- and proven to be effective in poor visibility conditions
- Anti-blooming mechanism
- External Video Synchronization (optional)
- User-friendly interface software
- Electronic Zoom x2, x4
- Flexible in adopting different optics
- Focus control through communication (optional)
- Digital Video Output (optional)



Features Description / Performance

Focal Plane Array Amorphous Silicon Micro-bolometer

Spectral range 8-14 µm

Number of Pixels 320x240

Pixel Size 35 µm

Analog Video Output CCIR or RS-170 (PAL or NTSC)

Digital Video Output (optional) 14 Bit RS422 or LVDS

Remote control RS 422 or RS 232

Control Operation Video Polarity, NUC, Video Format

Power consumption < 5W (average)

Operating Voltage 8-15 VDC (12 Nominal)

NETD ≤ 70° mK

Operating Temperature Range -20°C to +50°C

Dimensions (maximum) 75x90x115 (HxWxL)

Weight (engine only) < 180 g

Weight (with enclosure) < 1700 g

Environmental Qualification IP65 (IP 67- optional)

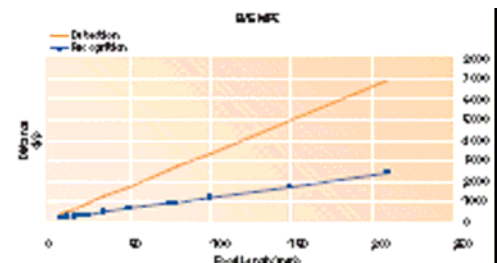

CHAO - N - JAMMING ACOSTIC SYSTEM

The **CHAOS-N** jamming acoustic system is designed to prevent unauthorized eavesdropping by any types of radiomicrophones, wired microphones, stethoscopes, dictaphones, directional microphones or any types of devices using the "microphone effect" or those subject to high-frequency imposing. The used garniture provides protection from "lips reading".

The system can be used as a stationary or a field device. It is designed for long continuous use.

Earphones with noise absorbing garnitures and special microphones

are used during negotiations. Audio signals from microphones are processed to cut off the noise component. Individual volume set up and on/off control are available. If intercepted, a speech of a user will represent a mixture of his own speech and the "speech noise" produced by the device. It is virtually impossible for an outsider to extract the initial user's speech from the noise mixture due to the fact, that the noise level significantly exceeds the level of the data signal. Using the volume control, the users can even whisper.

The type of the noise signal generated: voice (standard or synthesized, based on the preliminary recorded user's speech. The last option significantly diminishes the possibility for an outsider to recover the initial acoustic data).

An additional active acoustic system can be connected optionally.

The device is delivered in a shockproof waterproof case.



Specifications	
Type of the signal generated	Speech chorus
Number of users protected	2 ÷ 4
Number of users protected (the second system is connected)	Up to 8
Acoustic system output power, W	18
Outlet for the additional jamming acoustic system	High-resistance 3.5 mm
Maximum level of acoustic noise signal at 1 m distance, dB	102
Power supply, V/Hz	220/50
Power supply, car DC, V	12
Maximum current consumption, A	0.6
Dimensions, mm	300×250×120
Weight, kg	3.5

Complete set

- Main unit in protected case
- Set of users' garnitures
- AC/DC adapter
- Car DC cable

HSS -AV 2B — VIBRO -ACOUSTIC NOISE GENERATOR

The **HSS-AV 2B** is notable for the absence of a generator block, common for all oscillators — the generators of the jamming signal are built inside each of the oscillators.

The system is formed according to “a common power supply unit + generators-oscillators” principle.

The major advantage of these models is the significant increase of the stability of protection due to multi-generators independent launch of jamming signals in several points.



Specifications		
Generator-oscillator model	SA-65M	SV-45M
Output frequency range, Hz	175 ÷ 5600	90 ÷ 11,200
Current consumption, mA, not more than	20	
Maximum number of individual addresses	255	
Continuous operation time	Not limited	
Dimensions, mm	40×70×125	D=45, H=42
Weight, kg	0.3	0.3
Operation environment:		
■ operating temperatures range, °C	5 ÷ 40	
■ humidity (by t=25°C), %, up to	70	



The integral level and the spectrum of the noise, produced by the **SV-45** and **SA-65**.

Generators-oscillators, are corrected by the **HSS-PRG1** programmer, which is to be connected serially to the 12V power supply chain during setup.

The setup parameters are stored to the nonvolatile memory.



During the process of programming, the generators-oscillators are addressed individually, and the other units can be connected to the power supply. The address can be corrected by the HSS -PRG1. The noise spectrum is to be corrected by selecting one of 5 standard spectral models, which is not changed during integral level correction, and the level correction — discretely within 20 dB.

Specifications		
Power supply unit model	HSS-IP1	HSS-IP2
Number of independent channels*	2	
Nominal output voltage, V		
■ channel 1/channel 2	12/12	12**/12**
Voltage stabilizer	No	Yes
Maximum load current output	0.2+0.2	1+1
Number of generators-oscillators, connected at one time, pcs		
■ SV-45M	10+10	50+50
■ SA-65M	10+10	50+50
Remote control jack (interface)	Yes (HP "ON" contact +possibility for RC power supply 12V/30mA)	
Power supply, V/Hz	~220/50	
Dimensions of the block, mm	51×51×190	140×70×180
Weight of the block, kg	0.7	1.4
Operating environment:		
■ operating temperatures range, °C	5 ÷ 40	
■ humidity (by t=25°C), %, up to	70	
Continuous operation time	Not limited	



Security and Intelligence Advising

HSS-AV 1M / HSS -AV 2M VIBRO -ACOUSTIC NOISE GENERATORS

The **HSS-AV 1M** and the **HSS-AV 2M** noise generators are designed to prevent audio data leakage through acoustic and vibro-acoustic channels.

The devices provide countermeasures against the following possible threats:

- Eavesdropping due to improper sound isolation of premises
- Radio and wired microphones, installed inside walls, over false ceilings, in vent channels, etc.
- Stethoscopes fastened on the construction elements, such as walls, windows, floor, ceiling, as well as on the utility pipes (water, heat and gas pipes).
- Laser and microwave eavesdropping systems using the reflection from windows and interior elements.

The vibro-acoustic noise, produced by the HSS - AV generators, provides maximum jamming effect of voice signals; at the same time it guarantees minimum level of the audible noise during private negotiations. The generators possess two independent outputs for different operating loads, each of the outputs is equipped with regulators to preset vibro-and audio parameters of the jamming signal and its level.

Specifications		
Model	HSS -AV 1M	HSS -AV 2M
Number of independent channels	2	
Number of VI-45 vibro-acoustic transducers, connected at one time, pcs, not more than	20 (10+10)	40 (20+20)
Number of AI-65 audio jamming acoustic systems, connected at one time, pcs, not more than	16 (8+8)	20 (10+10)
Number of PI-45 vibro-acoustic transducers, connected at one time, pcs, not more than	16 (8+8)	
The frequency band of the produced jamming signal of guaranteed intensity, Hz	175 ÷ 5600	
Continuous operating time, hours, not less than	unlimited	
Power supply, V/Hz	220/50	
Dimensions of the main unit, mm	200×70×245	
Weight, kg	3.0	3.3

The generators sets include the **AI-65** audio jamming acoustic systems and the **VI-45** vibro-acoustic transducers, which are used to generate acoustic and vibration noise signals inside building constructions of the protected premises, and provide acceptable level of the audible noise.



The **PI-45** vibro-acoustic transducers are used to generate noise-jamming signals within windowpanes, doors and office. Wall partitions. These are specially designed low power electro-mechanical transducers.



HSS CI-C — MAINS PROTECTION NOISE GENERATOR

The **HSS CI-C** device is designed to prevent data leakage through the mains and to defeat covert audio surveillance devices, operated through the mains. The principle operation: the generator inputs a masking signal to one phase of the mains (220 V). The device does not affect the operation of the PCs and household electronics.

Specifications	
Spectrum density of the noise signal intensity within the frequency range (relative to $1 \mu\text{V}/\sqrt{\text{Hz}}$), dB, not less than	
■ 0.01 ÷ 10.0 MHz	55
■ 10.0 ÷ 20.0 MHz	45
■ 20.0 ÷ 30.0 MHz	40
Entropic noise quality factor, not less than	0.8
Power supply, V/Hz	220/50
Dimensions, mm	176×170×68
Weight, kg	1.0





Security and Intelligence Advising

PORTABLE FLAT PANEL X-RAY INSPECTION SYSTEM

Haboleshet SpyShop Ltd. offers a high-end Israeli made portable one-man operated X-RAY system.



The system integrates a-Si, (Amorphous Silicon), flat panel systems which are 100% portable, battery operated, DR- (digital radiography) and ruggedized laptop computer suitable for operation in almost any condition.

The system that provides real-time images upon request clearly have enormous time and cost advantages compared to any film-based or CR technology system. The unit provides immediate imaging with no processing or development time, no scanning time, cost free imaging and infinite and immediate re-shots.

The system is proven to be effective in the following industries:

- Air port security and customs
- VIP security
- Special Security Services
- Audio / Video surveillance detection once concealed inside concert wall
- Forensics

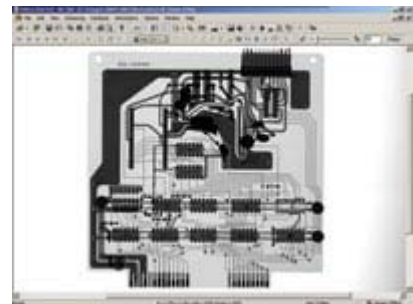

Standard configurations:

- State of the art ruggedized laptop computer
- Flat panel (2 models available)
- Imager unit (ICU) with cables to connect to the flat panel
- Proprietary software
- 50M lightweight cable on a removable reel attached inside a carrying case
- Ruggedized case on wheels or backpack carrying case with operation platform.
- X-RAY cable, charge cable and AC cable





Security and Intelligence Advising

BULLET PROOF PROTECTION GEAR

Haboleshet Spy Shop Ltd supplies a variety of military and security bullet protective products to accommodate the needs of our clients through out the world. We are always happy to meet our customer's requests including custom made solutions.

We offer large range of ballistic protective vests, clothing's, plates, and suitcases as well as combat hamess, military tents and several products of personal military / law enforcement professional equipment.

Ballistic protection

HSS1642B HBA204 HSS1600 HSS1600 HSS1692 HSS1103 HSS-MTI



Ballistic protective clothing

HSS-UKS HSS9020 HSS9010 HSS9040 HSS9050 HSS1540 HSS405501



Ballistic plates

Famstone Ceramic plate Formal plate anti knife stab



Bulletproof suitcase

Leather business briefcase



combat hamess

HSS1995

HSS5200

HSS5100





Security and Intelligence Advising

Ballistic Body Armor- Resistance Chart NIJ 0101.04 STD.

CALIBER	PROJECTILE	WEIGHT GRAINS	VELOCITY FT/SEC	VELOCITY M/SEC	NIJ LEVEL
38 SPECIAL	RN LEAD	158	850	260	I
38 SPECIAL+ P	SWC LEAD	158	950	290	I
22 LRHV	LEAD	40	1050	320	I
22 LRHV	LEAD	40	1200	365	II-A
9 MM	FMJ	124	1090	335	II-A
.357 MAG.	JSP	158	1250	381	II-A
.357 MAG.	JSP	158	1300	395	II-A
22 LRHV(R)	COPPER- PLATED LEAD	40	1450	440	II-A
9 MM	FMJ	124	1175	358	II
.357 MAG	JSP	158	1395	425	II
.357 MAG.	SJSP	125	1450	440	II
12 GAUGE	00 (BUCKSHOT)	9 (PEELET)	1350	410	II
.14 MAG	LEAD	210	1300	397	II
.44 MAG	SJSP	240	1180	360	II
9 MM LAPUA	FMC	123	1200	366	III-A
9 MM NORMA	FMJ	116	1150	351	III-A
9 MM GECO	FMC	123	1200	366	III-A
9 MM CANADIAN	FMJ	116	1250	381	III-A
9 MM ISRAEL			1200	366	III-A
9 MM CAVIM	FMJ		1110	339	III-A
.44 MAG	LEAD SWC- GC	240	1400	425	III-A
9 MM	FMJ	124	1400	425	III-A
9 MM SMG	SILVERTIP HP	115	1400	425	III-A
7.62 MM NETO (R)	USM BALL M80	150	2750	838	III
5.56 MM NETO (R)	USM BALL M855	62	3050	925	III
5.56 MM NETO (R)	USM BALL M193	55	3050	925	III

RN- ROUND NOSE

SWC- SEMI- EADCUTTER

FMJ- FULL MWTAL JACKET

JSP- LACKETED SOFT POINT

HP- HOLLOW

GC- GAS CHECK

AP- ARMOR PIERCING

SJHP- SEMI JACKETED HOLLOW

Other ballistic will be supplied on request



Security and Intelligence Advising

INVESTIGATION AEROSOL PRODUCTS

GUN SHOT POWDER RESIDUE TEST KIT (GSPR)



Is the newest critical crime scene investigative tool. GSPR allows a police officer to rapidly identify shooting suspects. GSPR is a simple and quick three (3) step test that provides immediate results to the question: "Did this suspect fire a gun?" This kit acts as a presumptive field test for residue containing nitrites which is typical to gun powder residue.



FERROTRACE



Forensic science is often asked to demonstrate any physical link between suspect and firearm or tool. Ferrotrace has the amazing ability to make this link by detecting trace amounts of ferrous metal on skin, even to the point of outlining the metal object on the skin (e.g., gun handle or grenade). The chemical reaction between the ferrous metal residue and Ferrotrace creates a purple colored corollary that is in the pattern of the object that was held in the hands.



SEE THROUGH



See Through can make a letter transparent to allow one to see the contents even to the point of being able to read print inside. The product does not damage the letter, or inks used. When See Through dries, no one knows that it has been used.



UV TRAP



UV Trap is a marking tool that leaves an invisible color residue on the surface that has been sprayed. When that surface is touched, the residue is transferred to the hands that touched the surface. Under the UV lamp, the residue is shown by a purple color on the skin. The residue will remain on the skin for some time, even when washed.



Blue



Blue is a unique tool for the development of footprints. Spraying directly on a non-porous surface will reveal the pattern of any undisturbed footprint that exists. The pattern will appear blue on a yellow background. It can be used on wooden, stone and linoleum floors and similar surfaces, which makes it an easy tool for footprint visualization, when casting is not an option.

